



JVC



VIDEO CASSETTE RECORDER

HR-A52U (Hi-Fi)

HR-A32U (Monaural)

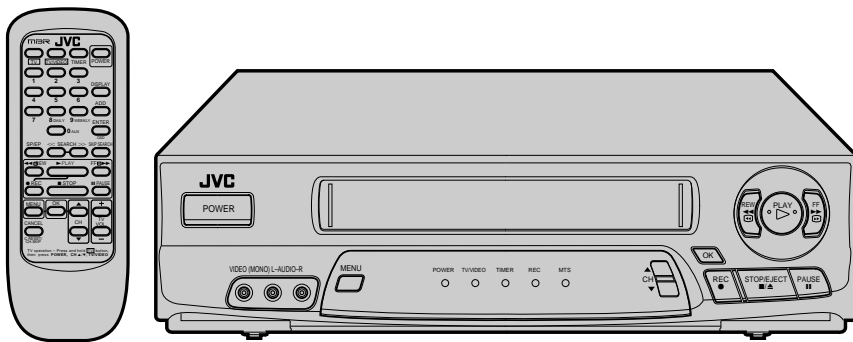

Hi-Fi



(The VCR illustrations appearing in this instruction manual are of the HR-A52U.)

INSTRUCTIONS

For Customer Use:

Enter below the Serial No. which is located on the rear of cabinet. Retain this information for future reference.



Model No. HR-A52U/HR-A32U

Serial No. _____

Dear Customer,

Thank you for purchasing the JVC VHS video cassette recorder. Before use, please read the safety information and precautions contained in the following pages to ensure safe use of your new VCR.

CAUTIONS

	CAUTION RISK OF ELECTRIC SHOCK DO NOT OPEN	
<p>CAUTION: TO REDUCE THE RISK OF ELECTRIC SHOCK, DO NOT REMOVE COVER (OR BACK). NO USER-SERVICEABLE PARTS INSIDE. REFER SERVICING TO QUALIFIED SERVICE PERSONNEL.</p>		



The lightning flash with arrowhead symbol, within an equilateral triangle, is intended to alert the user to the presence of uninsulated "dangerous voltage" within the product's enclosure that may be of sufficient magnitude to constitute a risk of electric shock to persons.



The exclamation point within an equilateral triangle is intended to alert the user to the presence of important operating and maintenance (servicing) instructions in the literature accompanying the appliance.

WARNING:

TO PREVENT FIRE OR SHOCK HAZARD, DO NOT EXPOSE THIS UNIT TO RAIN OR MOISTURE.

CAUTION:

This video cassette recorder should be used with AC 120V~, 60Hz only. To prevent electric shocks and fire hazards, DO NOT use any other power source.

CAUTION:

TO PREVENT ELECTRIC SHOCK, MATCH WIDE BLADE OF PLUG TO WIDE SLOT, FULLY INSERT.

ATTENTION:

POUR ÉVITER LES CHOCS ÉLECTRIQUES, INTRODUIRE LA LAME LA PLUS LARGE DE LA FICHE DANS LA BORNE CORRESPONDANTE DE LA PRISE ET POUSSER JUSQU'AU FOND.

Note to CATV system installer:

This reminder is provided to call the CATV system installer's attention to Article 820-40 of the NEC that provides guidelines for proper grounding and, in particular, specifies that the cable ground shall be connected to the grounding system of the building, as close to the point of cable entry as practical.

CAUTION:

Changes or modifications not approved by JVC could void user's authority to operate the equipment.

Failure to heed the following precautions may result in damage to the VCR, remote control or video cassette.

- DO NOT** place the VCR . . .
 - ... in an environment prone to extreme temperatures or humidity.
 - ... in direct sunlight.
 - ... in a dusty environment.
 - ... in an environment where strong magnetic fields are generated.
 - ... on a surface that is unstable or subject to vibration.
- DO NOT** block the VCR's ventilation openings.
- DO NOT** place heavy objects on the VCR or remote control.
- DO NOT** place anything which might spill on top of the VCR or remote control.
- AVOID** violent shocks to the VCR during transport.

****MOISTURE CONDENSATION**

Moisture in the air will condense on the VCR when you move it from a cold place to a warm place, or under extremely humid conditions—just as water droplets form on the surface of a glass filled with cold liquid. Moisture condensation on the head drum will cause damage to the tape. In conditions where condensation may occur, keep the VCR's power turned on for a few hours to let the moisture dry.

****ABOUT HEAD CLEANING**

Accumulation of dirt and other particles on the video heads may cause the playback picture to become blurred or interrupted. Be sure to contact your nearest JVC dealer if such troubles occur.



- Cassettes marked "VHS" (or "S-VHS") can be used with this video cassette recorder. However, only "VHS" recordings can be played back in this model.
- HQ VHS is compatible with existing VHS equipment.

IMPORTANT PRODUCT SAFETY INSTRUCTIONS

Electrical energy can perform many useful functions. But improper use can result in potential electrical shock or fire hazards. This product has been engineered and manufactured to assure your personal safety. In order not to defeat the built-in safeguards, observe the following basic rules for its installation, use and servicing.

ATTENTION:

Follow and obey all warnings and instructions marked on your product and its operating instructions. For your safety, please read all the safety and operating instructions before you operate this product and keep this booklet for future reference.

INSTALLATION

1. Grounding or Polarization

(A) Your product may be equipped with a polarized alternating-current line plug (a plug having one blade wider than the other). This plug will fit into the power outlet only one way. This is a safety feature.

If you are unable to insert the plug fully into the outlet, try reversing the plug. If the plug should still fail to fit, contact your electrician to replace your obsolete outlet. Do not defeat the safety purpose of the polarized plug.

(B) Your product may be equipped with a 3-wire grounding-type plug, a plug having a third (grounding) pin. This plug will only fit into a grounding-type power outlet. This is a safety feature.

If you are unable to insert the plug into the outlet, contact your electrician to replace your obsolete outlet. Do not defeat the safety purpose of the grounding-type plug.

2. Power Sources

Operate your product only from the type of power source indicated on the marking label. If you are not sure of the type of power supply to your home, consult your product dealer or local power company. If your product is intended to operate from battery power, or other sources, refer to the operating instructions.

3. Overloading

Do not overload wall outlets, extension cords, or integral convenience receptacles as this can result in a risk of fire or electric shock.

4. Power Cord Protection

Power supply cords should be routed so that they are not likely to be walked on or pinched by items placed upon or against them, paying particular attention to cords at plugs, convenience receptacles, and the point where they exit from the product.

5. Ventilation

Slots and openings in the cabinet are provided for ventilation. To ensure reliable operation of the product and to protect it from overheating, these openings must not be blocked or covered.

- Do not block the openings by placing the product on a bed, sofa, rug or other similar surface.
- Do not place the product in a built-in installation such as a bookcase or rack unless proper ventilation is provided or the manufacturer's instructions have been adhered to.

6. Wall or Ceiling Mounting

The product should be mounted to a wall or ceiling only as recommended by the manufacturer.

ANTENNA INSTALLATION INSTRUCTIONS

1. Outdoor Antenna Grounding

If an outside antenna or cable system is connected to the product, be sure the antenna or cable system is grounded so as to provide some protection against voltage surges and built-up static charges. Article 810 of the National Electrical Code, ANSI/NFPA 70, provides information with regard to proper grounding of the mast and supporting structure, grounding of the lead-in wire to an antenna discharge unit, size of grounding connectors, location of antenna discharge unit, connection to grounding electrodes, and requirements for the grounding electrode.

2. Lightning

For added protection for this product during a lightning storm, or when it is left unattended and unused for long periods of time, unplug it from the wall outlet and disconnect the antenna or cable system. This will prevent damage to the product due to lightning and power-line surges.

3. Power Lines

An outside antenna system should not be located in the vicinity of overhead power lines or other electric light or power circuits, or where it can fall into such power lines or circuits. When installing an outside antenna system, extreme care should be taken to keep from touching such power lines or circuits as contact with them might be fatal.

EXAMPLE OF ANTENNA GROUNDING AS PER NATIONAL ELECTRICAL CODE, ANSI/NFPA 70

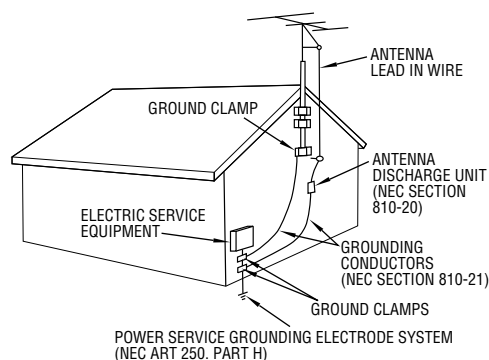

NEC - NATIONAL ELECTRICAL CODE



4

USE

1. Accessories

To avoid personal injury:

- Do not place this product on an unstable cart, stand, tripod, bracket, or table. It may fall, causing serious injury to a child or adult, and serious damage to the product.
- Use only with a cart, stand, tripod, bracket, or table recommended by the manufacturer or sold with the product.
- Use a mounting accessory recommended by the manufacturer and follow the manufacturer's instructions for any mounting of the product.
- Do not try to roll a cart with small casters across thresholds or deep-pile carpets.

2. Product and Cart Combination

A product and cart combination should be moved with care. Quick stops, excessive force, and uneven surfaces may cause the product and cart combination to overturn.

PORTABLE CART WARNING
(Symbol provided by RETAC)



3. Water and Moisture

Do not use this product near water—for example, near a bath tub, wash bowl, kitchen sink or laundry tub, in a wet basement, or near a swimming pool and the like.

4. Object and Liquid Entry

Never push objects of any kind into this product through openings as they may touch dangerous voltage points or short-out parts that could result in a fire or electric shock. Never spill liquid of any kind on the product.

5. Attachments

Do not use attachments not recommended by the manufacturer of this product as they may cause hazards.

6. Cleaning

Unplug this product from the wall outlet before cleaning. Do not use liquid cleaners or aerosol cleaners. Use a damp cloth for cleaning.

7. Heat

The product should be situated away from heat sources such as radiators, heat registers, stoves, or other products (including amplifiers) that produce heat.

SERVICING

1. Servicing

If your product is not operating correctly or exhibits a marked change in performance and you are unable to restore normal operation by following the detailed procedure in its operating instructions, do not attempt to service it yourself as opening or removing covers may expose you to dangerous voltage or other hazards. Refer all servicing to qualified service personnel.

2. Damage Requiring Service

Unplug this product from the wall outlet and refer servicing to qualified service personnel under the following conditions:

- a. When the power supply cord or plug is damaged.
- b. If liquid has been spilled, or objects have fallen into the product.
- c. If the product has been exposed to rain or water.
- d. If the product does not operate normally by following the operating instructions. Adjust only those controls that are covered by the operating instructions as an improper adjustment of other controls may result in damage and will often require extensive work by a qualified technician to restore the product to its normal operation.
- e. If the product has been dropped or damaged in any way.
- f. When the product exhibits a distinct change in performance—this indicates a need for service.

3. Replacement Parts

When replacement parts are required, be sure the service technician has used replacement parts specified by the manufacturer or have the same characteristics as the original part. Unauthorized substitutions may result in fire, electric shock or other hazards.

4. Safety Check

Upon completion of any service or repairs to this product, ask the service technician to perform safety checks to determine that the product is in safe operating condition.

HOW TO USE THIS INSTRUCTION MANUAL

- All major sections and subsections are listed in the Table Of Contents on page 5. Use this when searching for information on a specific procedure or feature.
- The Index on pages 33–35 lists frequently-used terms, and the number of the first page on which they are used or explained in the manual. This section also illustrates the controls and connections on the front and rear panel, the front panel indicators and the remote control.
- The  mark signals a reference to another page for instructions or related information.
- Operation buttons necessary for the various procedures are clearly indicated through the use of illustrations at the beginning of each major section.

BEFORE YOU INSTALL YOUR NEW VCR . . .

. . . please read the sections/literature listed below.

- "Cautions" on page 2
- "Important Products Safety Instructions" on the previous pages



CONTENTS

I NSTALLING YOUR NEW VCR **6**

Basic Connections 6

I NITIAL SETTINGS **7**

Clock 7

Preparation 7

Language Select 7

Clock Setting 8

Tuner 9

Set Receivable Channels 9

Add Or Delete A Channel 11

S IMPLE PLAYBACK AND RECORDING **12**

Simple Playback 12

Simple Recording 13

P LAYBACK AND RECORDING FEATURES **14**

Playback 14

Still Picture 14

Slow, Reverse, Reverse Slow Or Fast-Motion

Picture 14

Manual Tracking 15

Select The Soundtrack (HR-A52U ONLY) 16

Superimpose 17

Skip Search 18

Repeat Playback 18

Index Search 18

Counter Reset 19

Tape Position Indicator 19

Next-Function Memory 19

Recording 20

Record One Program While

Watching Another 20

Display Elapsed Recording Time 20

Stereo And SAP (Second Audio Program)

(HR-A52U ONLY) 21

To Record SAP Programs (HR-A52U ONLY) ... 21

T IMER RECORDING **22**

Instant Timer Recording (ITR) 22

On-Screen Timer Programming 22

Check And Cancel Programs 24

Auto Timer 25

E DITING **26**

Edit To Or From Another VCR 26

Edit From A Camcorder 27

Assemble Editing 28

S PECIAL FEATURES **29**

Control A JVC TV With The VCR's

Remote 29

T ROUBLESHOOTING **30**

Power 30

Tape Transport 30

Playback 30

Recording 30

Timer Recording 31

Other Problems 31

Q UESTIONS AND ANSWERS **32**

Playback 32

Recording 32

Timer Recording 32

I NDEX **33**

List Of Terms 33

Front View 34

Rear View 34

Front Panel Indicators 35

Remote Control 35

S PECIAL FEATURES **36**

F OR SERVICING **37**

W ARRANTY **38**

Basic Connections

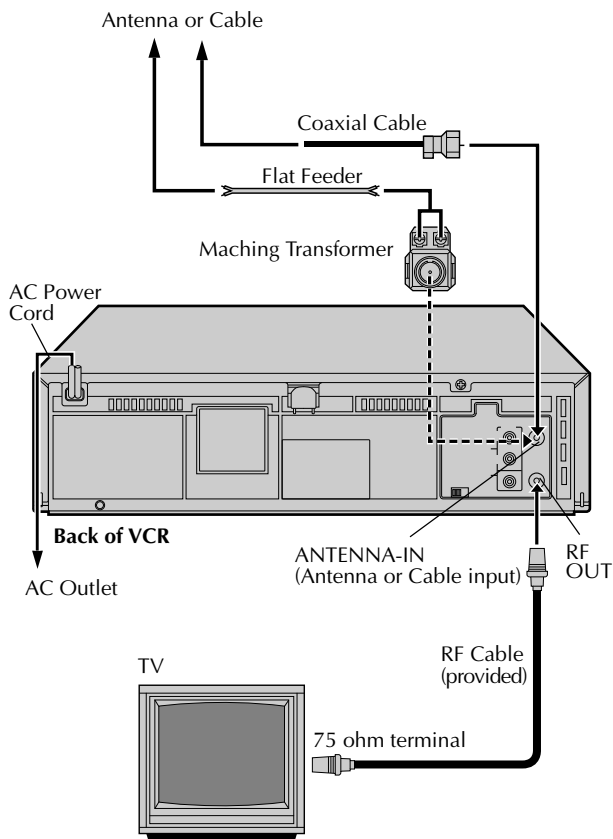

Back of VCR

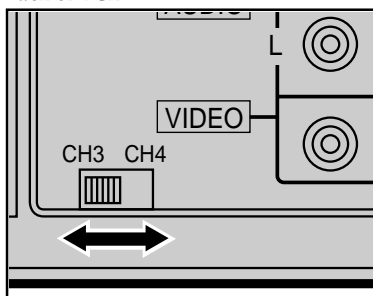

1

CHECK CONTENTS

Make sure the package contains all of the accessories listed in "SPECIFICATIONS" (☞ pg. 36).

2

SITUATE VCR

Place the VCR on a stable, horizontal surface.

3

CONNECT VCR TO TV

The connection method you use depends on the type of TV you have.

RF Connection

- To Connect To A TV With NO AV Input Terminals . . .
 - a- Disconnect the TV antenna cable from the TV.
 - b- Connect the TV antenna cable to the ANT IN jack on the rear of the VCR.
 - c- Connect the supplied RF cable between the RF OUT jack on the rear of the VCR and the TV's antenna terminal.

AV Connection

- To Connect To A TV With AV Input Terminals . . .
 - a- Connect the antenna, VCR and TV as shown in the illustration.
 - b- Connect an Audio/Video Cable (not supplied) between the AUDIO OUT and VIDEO OUT jacks on the rear of the VCR and the AV IN jacks on the TV.

4

CONNECT VCR TO POWER SOURCE

Connect the power plug to an AC outlet.

5

FINAL PREPARATION FOR USE

Select the VCR channel (3 or 4) by setting the switch on the rear of the VCR as shown in the illustration.

Turn on the TV's power. You are now able to perform simple playback (☞ pg. 12) and recording (☞ pg. 13).

NOTES:

- The VCR channel is the channel on the TV which will display the audio and video signals from the VCR. The VCR's CH3-CH4 switch sets the VCR channel to CH3 or CH4.
- The CH3-CH4 switch is preset to the CH3 position. Set to CH4 if CH3 is used for broadcasting in your area.
- If your TV has no AV input terminals, set the channel on the TV to correspond to the CH3-CH4 switch on the back of the VCR.
- Even if your TV has AV input terminals, you must connect it to the VCR using an RF cable in order to record one show while watching another (☞ pg. 20).
- For full identification of the VCR's rear panel, refer to the Index (REAR VIEW ☞ pg. 34).

Clock

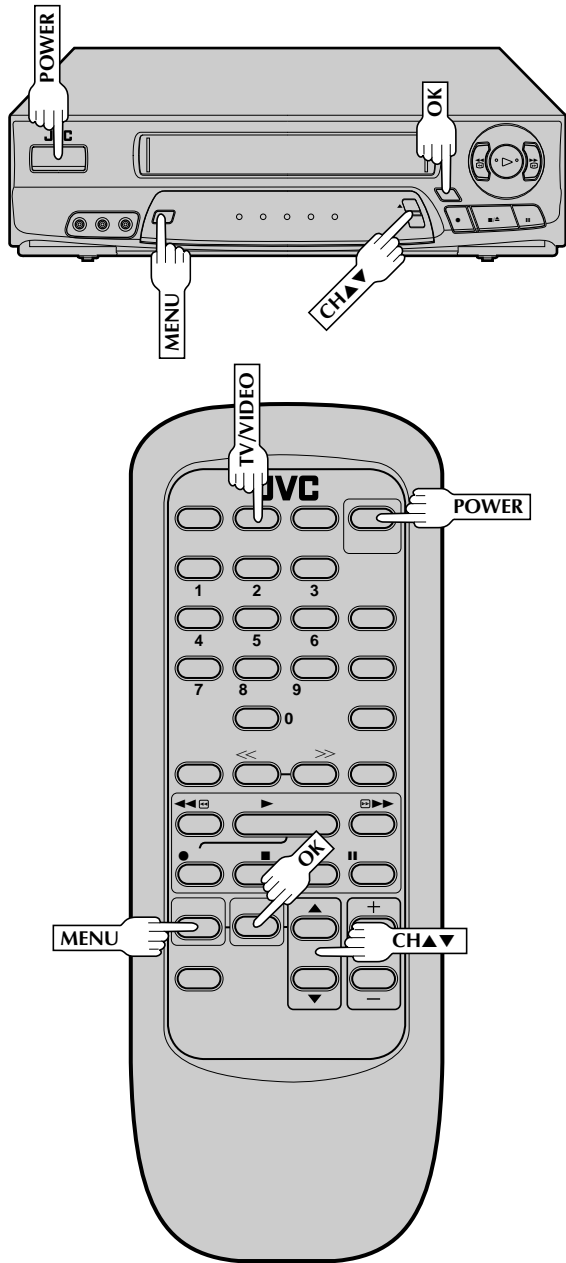

Preparation

1

TURN ON THE VCR

Press **POWER**. If watching channel 3 or 4, press **TV/VIDEO** to select the VIDEO mode. The TV/Video indicator on the front panel lights.

2

ACCESS ON-SCREEN MENU

Press **MENU** to bring up the Main Menu screen.

3

ACCESS INITIAL SET SCREEN

At the Main Menu screen, place the arrow next to "INITIAL SET" by pressing **CH▲▼**, then press **OK**.

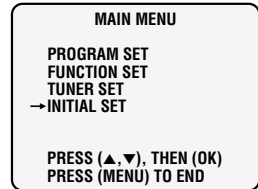

Language Select

1

ACCESS LANGUAGE SELECT SCREEN

The messages are preset to appear in English. If you want to see them in Spanish or French, place the arrow next to "LANGUAGE SELECT" by pressing **CH▲▼**, then press **OK**.



2

SELECT LANGUAGE

At the Language Select screen, place the arrow next to the desired language by pressing **CH▲▼**, then press **MENU**. The Initial Set screen reappears.



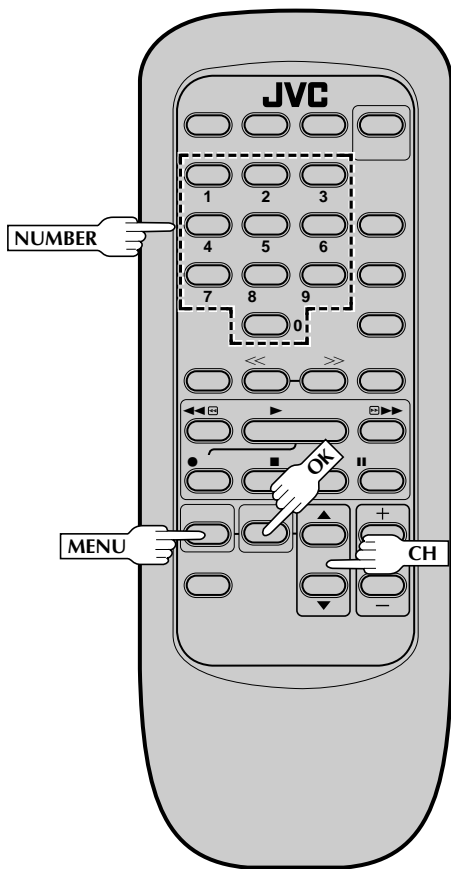
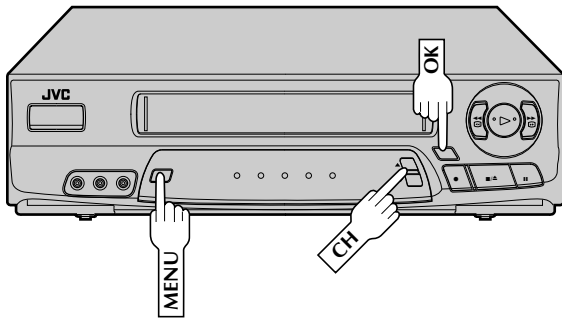

Clock Setting

1 ACCESS CLOCK SET SCREEN

Place the arrow at the Initial Set screen next to "CLOCK SET" by pressing **CH▲▼**, then press **OK**.



2 SET DATE, TIME AND D.S.T.

Press the appropriate **NUMBER** keys to set the date and time (if only 1 digit, press "0" first). Press **CH▲▼** to set AM/PM and D.S.T. (Daylight Saving Time) to "ON" (automatic adjustment based on VCR's clock) or "OFF" (if D.S.T. doesn't apply to you).

Press **OK** after AM/PM and D.S.T. settings. The next setting that can be set begins flashing. When you're finished with this set-up procedure, press **MENU** to start the clock.

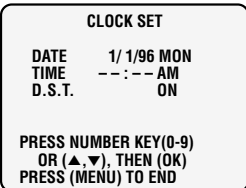

NOTE:

CH▲▼ can be used to perform all operations. (In this case, press **OK** after each setting.)

3 MAKE CORRECTIONS

To change any of the settings, press **OK** until the item you want to change blinks, then set as in step 2.

Tuner

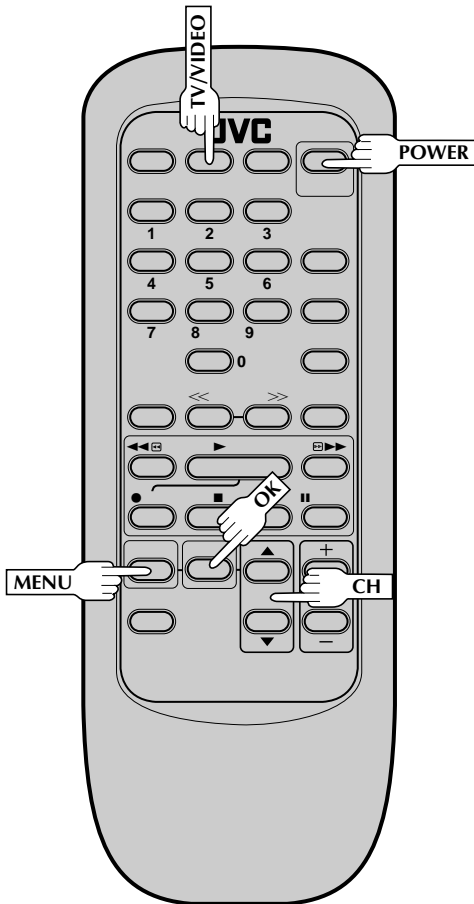
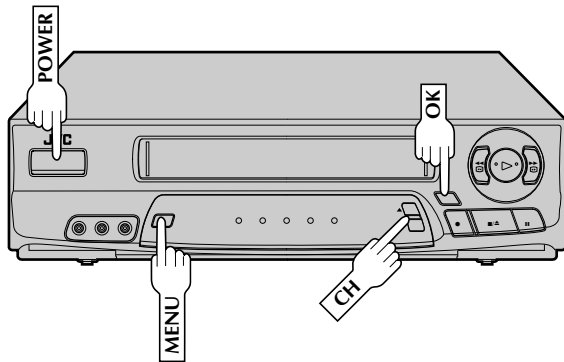

Set Receivable Channels

1

TURN ON THE VCR

Press **POWER**. If watching on channel 3 or 4, press **TV/VIDEO** to select the VIDEO mode. The TV/Video indicator on the front panel lights.

2

ACCESS MAIN MENU SCREEN

Press **MENU**.

3

ACCESS TUNER SET SCREEN

Place the arrow next to "TUNER SET" by pressing **CH▲▼**, then press **OK**.

4

ACCESS BAND SCREEN

Place the arrow next to "BAND" by pressing **CH▲▼**, then press **OK**.



5

SET FREQUENCY BAND

If you receive your TV channels from an external antenna, select "TV". If you receive your TV channels from a cable TV system, select "CATV".

Place the arrow next to your choice by pressing **CH▲▼**, then press **MENU** to return to the Tuner Set screen.

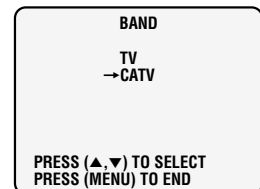

CONTINUED ON NEXT PAGE.

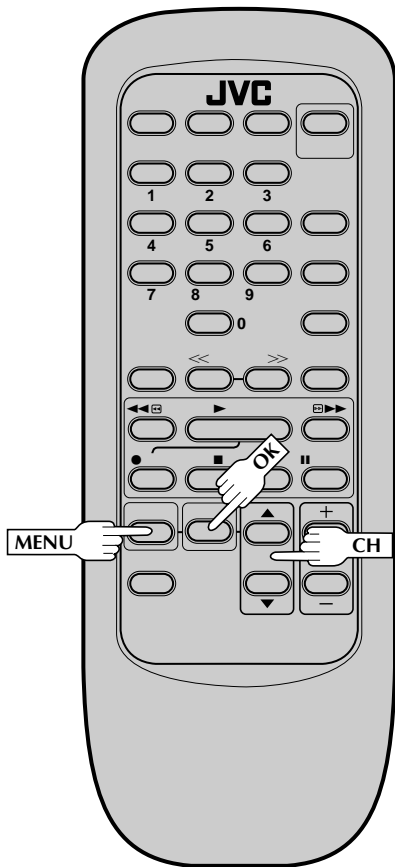
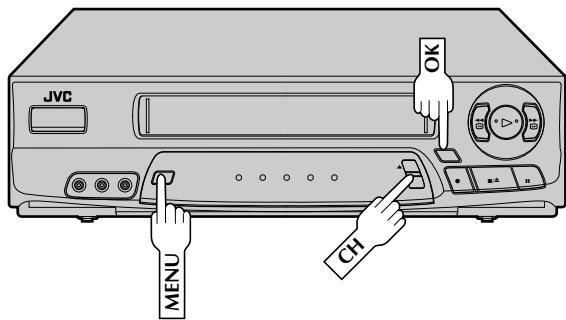

6

PERFORM AUTO CHANNEL SET

Place the arrow next to "AUTO CHANNEL SET" by pressing **CH▲▼**, then press **OK**. Receivable channels in your area are automatically assigned to the **CH▲▼** buttons, and non-receivable channels are skipped.

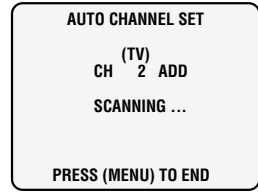

NOTES:

- At the end of Auto Channel Set, "SCAN COMPLETED" appears on screen.
- If the scan was unsuccessful, "SCAN COMPLETED-NO SIGNAL" appears on screen. Check the band setting and connections and start again.

7

RETURN TO NORMAL SCREEN

Press **MENU** as many times as necessary.

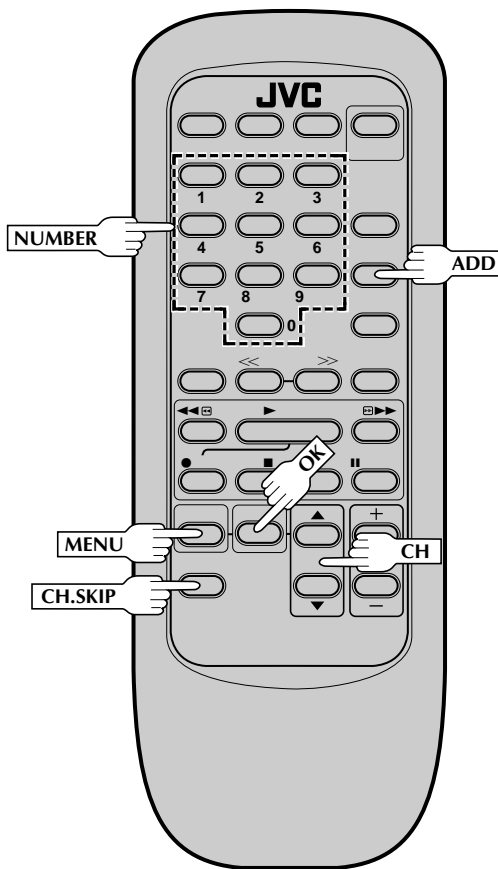
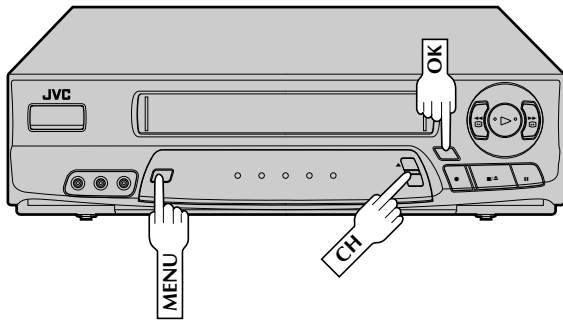

Add Or Delete A Channel

1

ACCESS TUNER SET SCREEN

Access by performing steps 2 and 3 of the Tuner procedure on page 9.

- To add a channel, go to step 2.
- To delete a channel, skip to step 4.

2

ACCESS AFC SCREEN

Place the arrow next to "AFC" by pressing **CH▲▼**, then press **OK**.

3

MAKE SELECTION

Place the arrow next to "SPCL" by pressing **CH▲▼**, then press **MENU** to return to the Tuner Set screen.

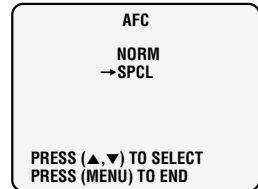

4

ACCESS MANUAL CHANNEL SET SCREEN

Place the arrow next to "MANUAL CHANNEL SET" by pressing **CH▲▼**, then press **OK**.

5

STORE DESIRED CHANNEL

Input the channel number using the **NUMBER** keys or by pressing **CH▲▼**, then press **ADD** to add or **CH.SKIP** to delete. Repeat for each channel you want to store or skip.

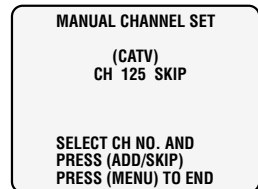

6

RETURN TO NORMAL SCREEN

Press **MENU** as many times as necessary.

Simple Playback

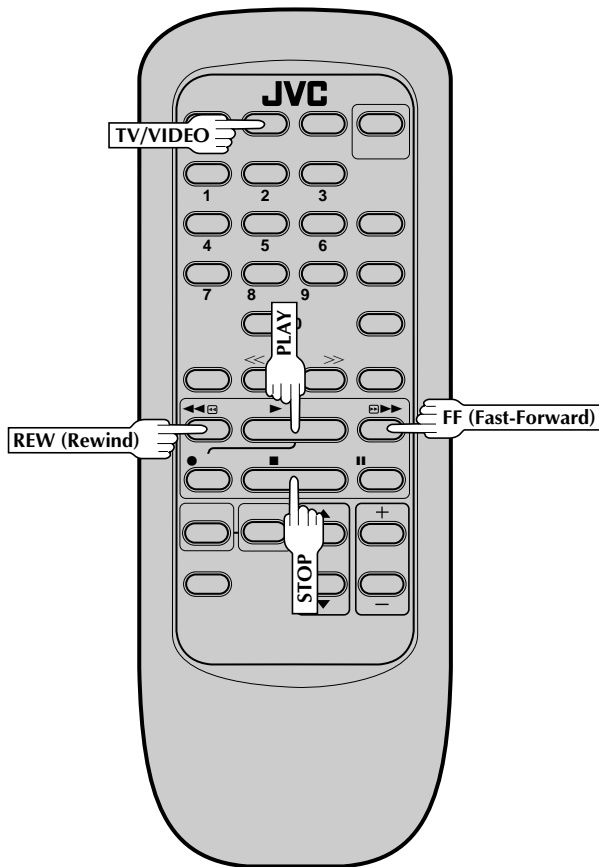
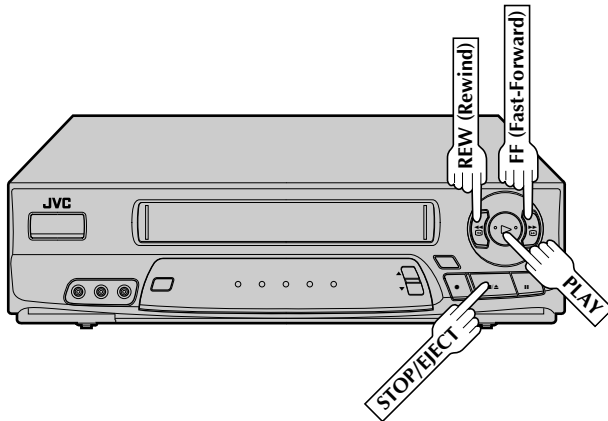

1 LOAD A CASSETTE

Make sure the window side is up, the rear label side is facing you and the arrow on the front of the cassette is pointing towards the VCR. Don't apply too much pressure when inserting.

- The VCR's power comes on automatically.
- If watching channel 3 or 4, press TV/VIDEO to select the VIDEO mode. The TV/Video indicator on the front panel lights.
- The counter is automatically reset to "0:00:00".
- If the cassette's record safety tab has been removed, playback begins automatically.

2 FIND PROGRAM START POINT

If the tape is advanced past the start point, press **REW**. To go forward, press **FF**.

3 START PLAYBACK

Press **PLAY**.

4 STOP PLAYBACK

Press **STOP** or **STOP/EJECT**. Then press **STOP/EJECT** to remove the cassette.

Usable cassettes

Full-Size VHS
T-30 (ST-30**)
T-60 (ST-60**)
T-90
T-120 (ST-120**)
T-160 (ST-160**)
ST-210**

Compact VHS*
TC-20 (ST-C20**)
TC-30 (ST-C30**)
TC-40 (ST-C40**)

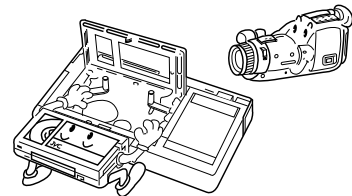

* Compact VHS camcorder recordings can be played on this video recorder. Simply place the recorded cassette into a VHS Cassette Adapter and it can be used just like any full-sized VHS cassette.

** This video recorder can record on regular VHS and Super VHS cassettes. However, it will record and playback regular VHS signals only. It is not possible to playback Super VHS recordings.

Simple Recording

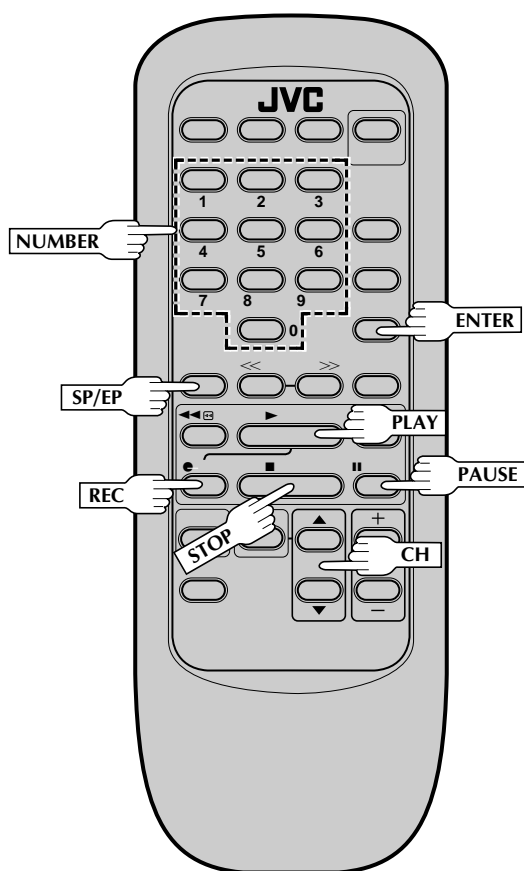
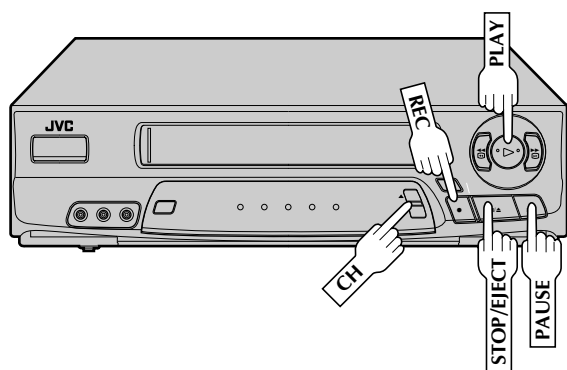

1 LOAD A CASSETTE

Make sure the record safety tab is intact. If not, cover the hole with adhesive tape before inserting the cassette.

2 SELECT RECORDING CHANNEL

Press **CH**▲▼. Or press the appropriate **NUMBER** keys, then press **ENTER**. (The channel changes after a few seconds whether you press **ENTER** or not.)

3 SET TAPE SPEED

Press **SP/EP** to set the recording speed.

4 START RECORDING

Press **REC** and **PLAY** on the remote control together, or press **REC** on the VCR's front panel.

5 PAUSE/RESUME RECORDING

Press **PAUSE**. Press **PLAY** to resume recording.

6 STOP RECORDING

Press **STOP** or **STOP/EJECT**. Then press **STOP/EJECT** to remove the cassette.

Accidental erasure prevention

- To prevent accidental recording on a recorded cassette, remove its record safety tab. To record on it later, cover the hole with adhesive tape.

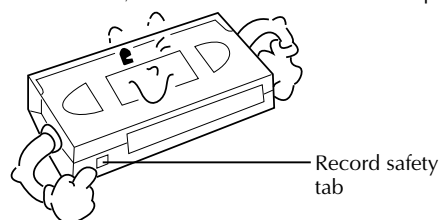



Playback

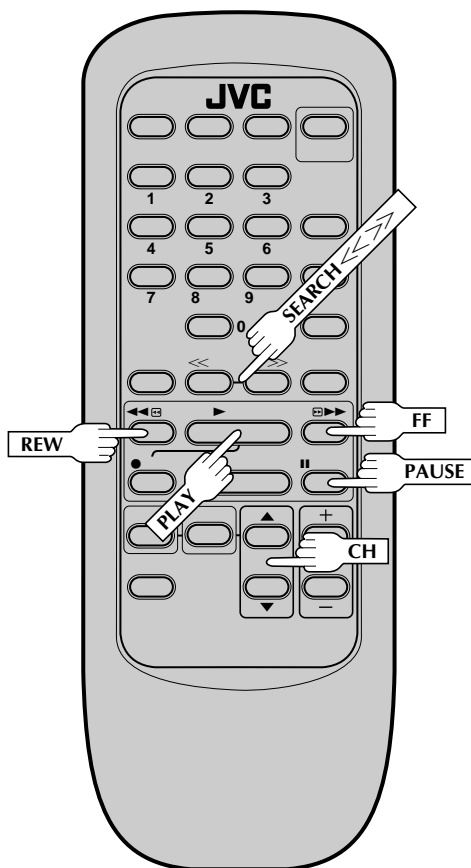
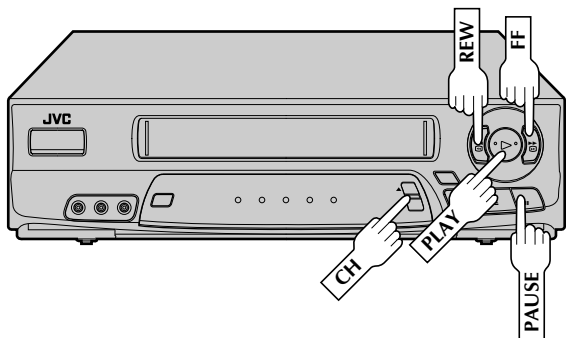

Still Picture

1 PAUSE DURING PLAYBACK

Press **PAUSE**. If there is vertical jitter, press **CH▲** or **▼** on the VCR's front panel or remote to stabilize the picture.

2 FRAME-BY-FRAME PLAYBACK

Advance the tape one frame by pressing **PAUSE** again.

- To control the direction of Frame-by-Frame Playback, press **SEARCH<<** or **>>** during still picture mode.

3 RESUME NORMAL PLAYBACK

Press **PLAY** during still picture mode.

Slow, Reverse, Reverse Slow Or Fast-Motion Picture

1 DURING PLAYBACK

Press **SEARCH<<** or **>>**.

- To increase the speed in the forward direction, press **>>**.
- To decrease the speed in the forward direction, press **<<**.
- To play in reverse slow motion, and in reverse play mode, continue to press **<<** after selecting all the forward slow motion modes.

Press **FF** for forward fast motion, or **REW** for reverse fast motion.

2 RESUME NORMAL PLAYBACK

Press **PLAY**.

NOTES:

- Press and hold **FF** or **REW** for more than 2 seconds for short fast-motion searches. When the button is released, normal playback resumes.
- If noise bars appear during playback or slow motion, correct using manual tracking. (☞ pg. 15).



Manual Tracking

Once playback begins, the VCR's automatic tracking function is engaged. If noise appears in the picture, you can override this and make the adjustment manually.

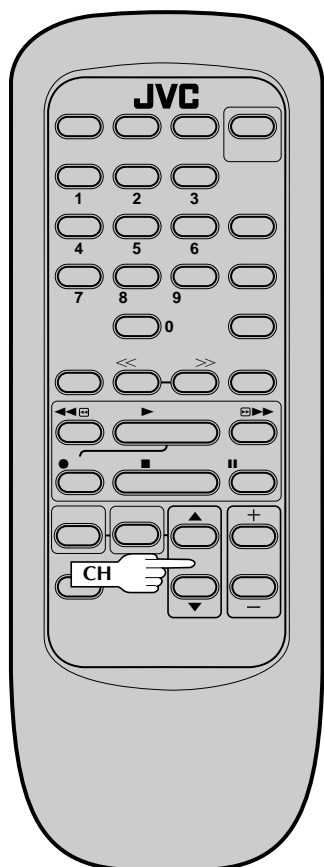
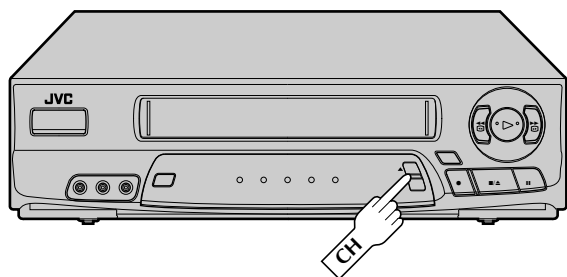

ENGAGE MANUAL TRACKING MODE

- 1 During playback, press the **CH▲▼** buttons on the VCR's front panel simultaneously to cancel the automatic tracking mode and enable manual tracking adjust.

ADJUST MANUAL TRACKING

- 2 Press **CH▲▼** on the VCR's front panel or remote. Press lightly for fine adjust, or press and hold for coarse adjust. Watch the screen and continue adjusting until optimum picture and sound quality are achieved.

RE-ENGAGE AUTOMATIC TRACKING

- 3 Press the **CH▲▼** buttons on the VCR's front panel simultaneously.

NOTE:

During slow-motion playback, simply press **CH▲** or **▼** on the VCR's front panel or remote to adjust tracking.

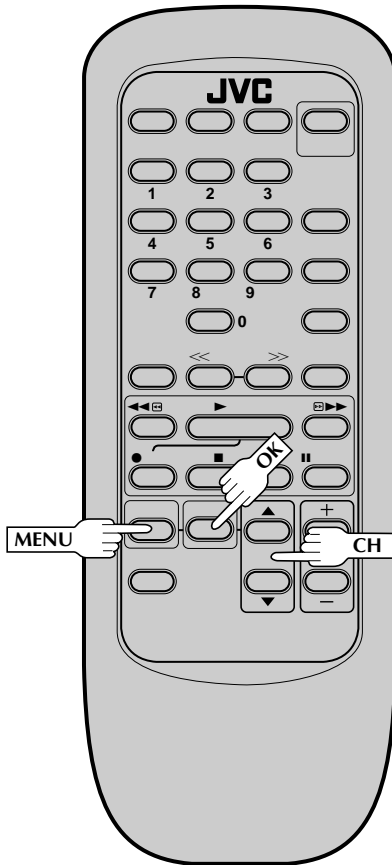
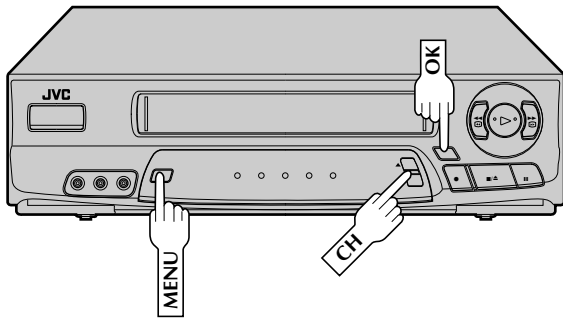
**(HR-A52U ONLY)****Select The Soundtrack**

Your VCR can record two soundtracks simultaneously (Normal and Hi-Fi) and play back the selected one, or both together.

1**ACCESS MAIN MENU SCREEN**

Press **MENU** during playback or when VCR is in stop mode.

2**ACCESS FUNCTION SET SCREEN**

Place the arrow next to "FUNCTION SET" by pressing **CH▲▼**, then press **OK**.

3**ACCESS AUDIO MONITOR SCREEN**

Place the arrow next to "AUDIO MONITOR" by pressing **CH▲▼**, then press **OK**.

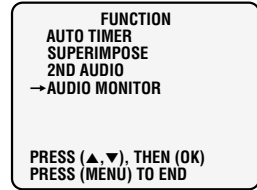
**4****SELECT MODE**

You have three choices:

- a- Hi-Fi
- b- Normal
- c- Mix

Place the arrow next to your choice by pressing **CH▲▼**.

**5****RETURN TO NORMAL SCREEN**

Press **MENU** as many times as necessary.

NOTE:

If the tape being played back has no Hi-Fi soundtrack, the Normal soundtrack will be heard no matter what choice you make at the Audio Monitor screen.

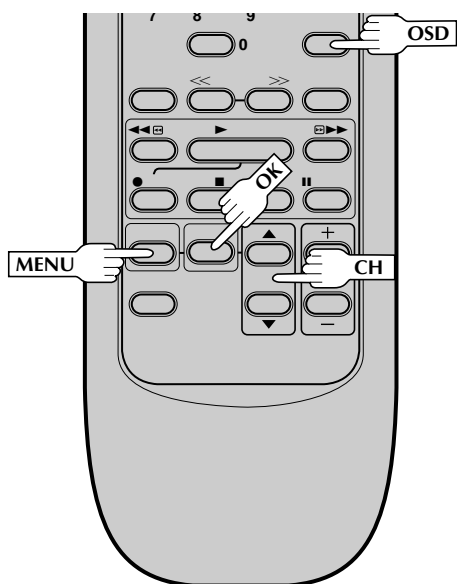
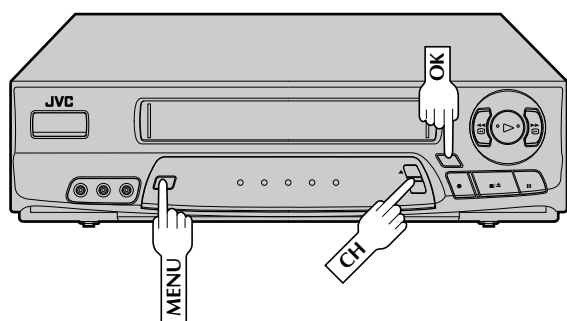

To recall an indication

- 1 Press **OSD**.
 - All indications corresponding to the current status are displayed for 5 seconds, leaving the counter information, and RECORD/PAUSE if in the Record Pause mode, on the screen. (No indication during still and search.)
- 2 Press **OSD** again to clear the display.

Superimpose

This function, switchable between ON and OFF, determines whether or not operational indicators will appear on screen.

- 1 **ACCESS MAIN MENU SCREEN**
Press **MENU**.
- 2 **ACCESS FUNCTION SET SCREEN**
Place the arrow next to "FUNCTION SET" by pressing **CH▲▼**, then press **OK**.
- 3 **ACCESS SUPERIMPOSE SCREEN**
Place the arrow next to "SUPERIMPOSE" by pressing **CH▲▼**, then press **OK**.

FUNCTION
AUTO TIMER
→SUPERIMPOSE
2ND AUDIO
AUDIO MONITOR

PRESS (▲,▼), THEN (OK)
PRESS (MENU) TO END

* In the case of the HR-A32U, "2ND AUDIO" and "AUDIO MONITOR" do not appear in the Function screen.
- 4 **SELECT MODE**
Place the arrow next to "ON" or "OFF" by pressing **CH▲▼**.

SUPERIMPOSE
→ON
OFF

PRESS (▲,▼) TO SELECT
PRESS (MENU) TO END
- 5 **RETURN TO NORMAL SCREEN**
Press **MENU** as many times as necessary.

NOTE:

If you engage the Record Pause mode, RECORD/PAUSE is displayed whether "SUPERIMPOSE" is set to "ON" or "OFF".

The superimposed indication on the TV screen tells you what the VCR is doing.

<p>Tuned-in channel or AUX(iliary) mode When the channel is changed, the new channel is displayed on the screen for 5 seconds.</p> <p>Clock time</p> <p>Tape position indicator</p> <p>"Cassette Loaded" mark When a cassette is loaded, the mark is displayed for 5 seconds. It blinks when the VCR's EJECT button is pushed.</p>	<div style="border: 1px solid black; padding: 5px; width: fit-content; margin: 0 auto;"> <p>CH 125 RECORD PAUSE</p> <p>THU 12:00 AM [CO] SP</p> <p style="text-align: center;">B-----+-----E</p> <p>NORM INDEX-1</p> <p>[HI-FI] COUNT -1:23:45</p> <p>Audio mode indicators (HR-A52U ONLY)</p> </div>	<p>Operation mode When the operation mode is changed, the new mode is displayed — RECORD (5 sec.), PLAY (5 sec.), FF/REW (5 sec. when engaged from Stop mode), RECORD PAUSE (for as long as Pause is engaged), and ITR **:*(5 sec.).</p> <p>Tape speed indicator</p> <p>INDEX indication</p> <p>Counter reading</p>
--	--	---

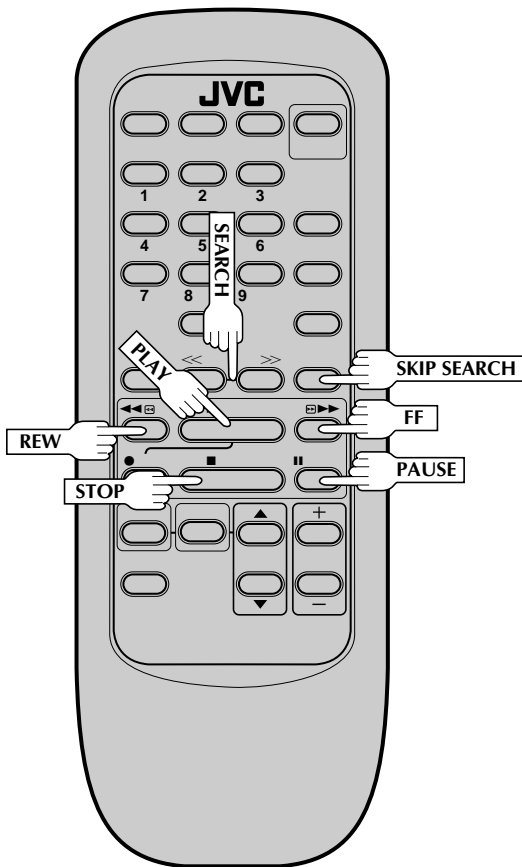
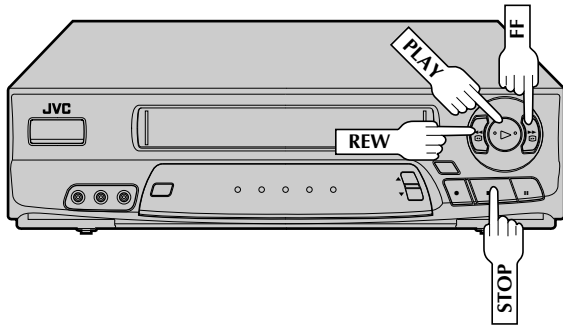

Skip Search

1 SKIP OVER UNWANTED SECTIONS

Press **SKIP SEARCH** 1 to 4 times during playback. Each press initiates a 30-second period of fast-motion playback. Normal playback resumes automatically.

NOTE:

To return to normal playback during a Skip Search, press **PLAY**.

Repeat Playback

1 START REPEAT

Press and hold **PLAY** during playback, then release.

- "PLAY" appears on screen and blinks for 5 seconds.
- The entire tape is played back 20 times.

2 STOP REPEAT

To stop, press **STOP** at any time.

NOTE:

Pressing **PLAY**, **REW**, **FF** or **PAUSE** also stops Repeat Playback.

Index Search

This function seeks out index codes that are placed on the tape at recording start.

1 START SEARCH

While the tape is stopped, press **SEARCH** << or >>.

2 ACCESS DISTANT CODE

To access a recording 2–9 index codes away, press **SEARCH** << or >> repeatedly until the correct number is displayed on screen (only if **SUPERIMPOSE** is set to ON (pg. 17)). Playback begins automatically when desired recording is located.

- To find the very beginning of the desired program, press **REW** or **FF** and search visually for the start point.

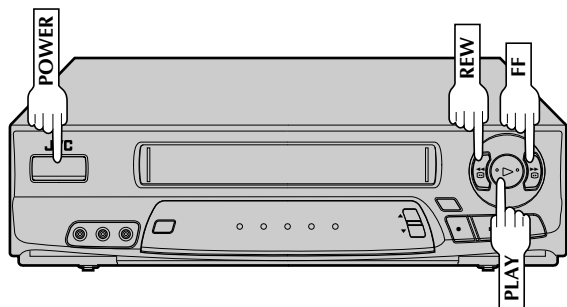

Counter Reset

1

RESET COUNTER TO ZERO

Press C.RESET.

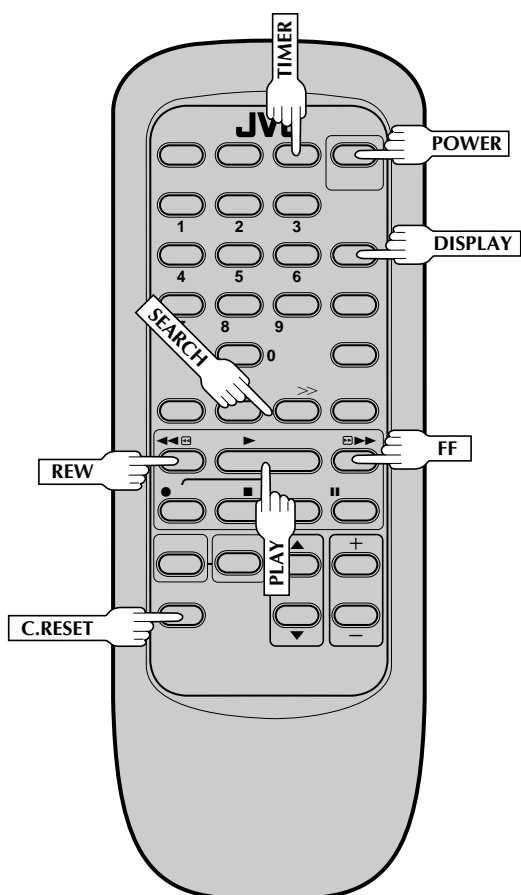

Tape Position Indicator

The Tape position indicator appears on screen when, from the stop mode, you press **FF**, **REW** or perform an Index Search. The position of "■" in relation to "B" (Beginning) or "E" (End) shows you where you are on the tape.

** SUPERIMPOSE must be set to ON, or the indicator will not appear (☞ pg. 17).

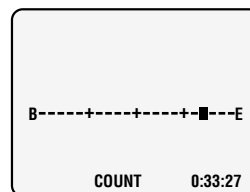

Next-Function Memory

The Next Function Memory "tells" the VCR what to do after rewinding.

- * Before continuing, ensure that the VCR is in stop mode.
- a-** For Automatic Start Of Playback After Tape Rewind . . .
 . . . press **REW**, then press **PLAY** within 2 seconds.
- b-** For Automatic Power Off After Tape Rewind . . .
 . . . press **REW**, then press **POWER** within 2 seconds.
- c-** For Automatic Timer Standby After Tape Rewind . . .
 . . . press **REW**, then press **TIMER** within 2 seconds.



Recording

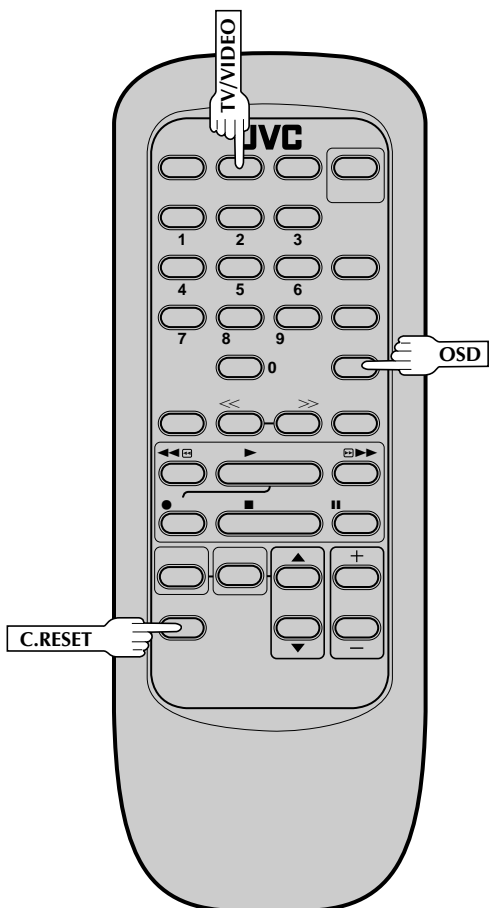
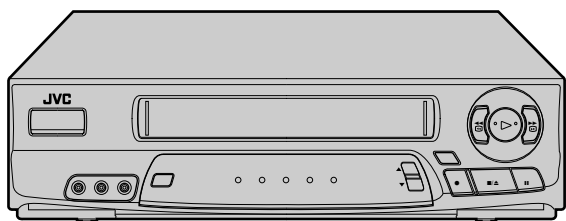

Record One Program While Watching Another

1 ENGAGE TV MODE

During recording...

- If using the RF connection (☞ pg. 6), press **TV/VIDEO**. The VCR's TV/Video indicator goes out and the TV broadcast being recorded disappears.
- If using the AV connection (☞ pg. 6), change the TV's input mode from AV to TV.

2 SELECT CHANNEL FOR VIEWING

Use the TV's channel selector to set the channel you want to watch.

Display Elapsed Recording Time

1 RESET COUNTER TO ZERO

Before recording starts, press **C.RESET**. The counter resets to zero.

2 DISPLAY ELAPSED TIME ON SCREEN

During recording, press **OSD** at any time to see the elapsed time. All indications corresponding to the current status of the VCR are displayed for 5 seconds. The counter display remains on the screen indicating the elapsed time. Press **OSD** again to remove the display.

- Make sure "SUPERIMPOSE" is set to "ON" (☞ pg. 17).

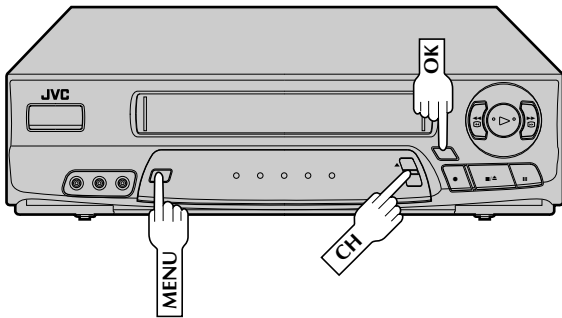

(HR-A52U ONLY) Stereo And SAP (Second Audio Program)

Your VCR's built-in MTS decoder enables reception of Multi-channel TV Sound broadcasts.

The MTS indicator lights during reception of stereo or SAP broadcasts, and when a stereo broadcast is accompanied by SAP audio.

To Record Stereo Programs . . .

. . . simply follow the basic recording procedure.

To Listen To Stereo Soundtrack During Recording . . .

. . . select "HI-FI" at the Audio Monitor screen (pg. 16).

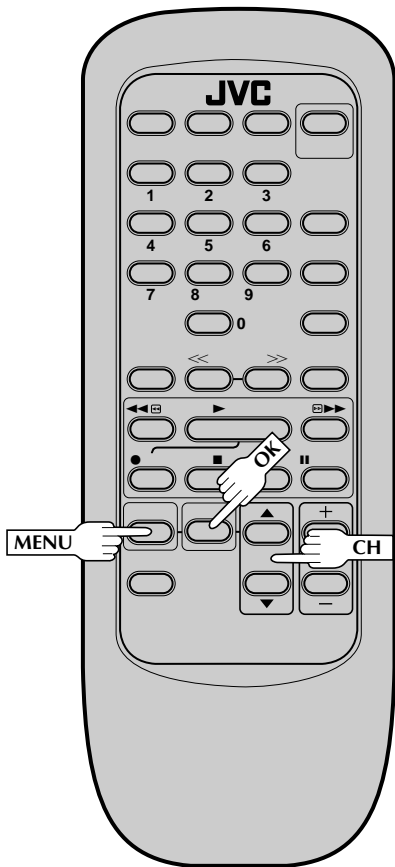

(HR-A52U ONLY) To Record SAP Programs . . .

1 ACCESS MAIN MENU SCREEN

Press MENU.

2 ACCESS FUNCTION SET SCREEN

Place the arrow next to "FUNCTION SET" by pressing CH▲▼, then press OK.

3 ACCESS 2ND AUDIO SCREEN

Place the arrow next to "2ND AUDIO" by pressing CH▲▼, then press OK.

4 SELECT MODE

Place the arrow next to "ON" by pressing CH▲▼.

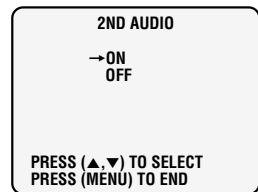

5 RETURN TO NORMAL SCREEN

Press MENU as many times as necessary.

NOTES:

- If a SAP program is received, the SAP audio is recorded on both the Normal and Hi-Fi tracks. The main audio program is not recorded.
- If a non-SAP program is received, the main audio is recorded on both the Hi-Fi and Normal audio tracks.



Instant Timer Recording (ITR)

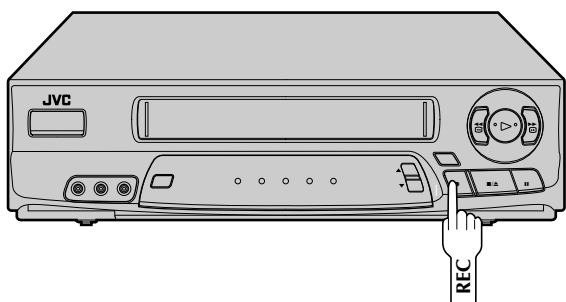

This easy method lets you record for from 30 minutes to 6 hours (selectable in 30-min. increments), and shuts the VCR off after recording is finished.

START RECORDING

Press **REC**.

ENGAGE ITR MODE

Press **REC** again. "ITR 0:30" appears on screen and blinks for about 5 seconds.

SET RECORDING DURATION

If you want to record for more than 30 minutes, press **REC** to extend the time. Each press extends recording time by 30 minutes.

NOTES:

- You can only perform ITR using the **REC** button on the VCR's front panel.
- To check remaining recording time, press **REC** once during recording and the remaining time is displayed for about 5 seconds on screen. Be careful not to press again during this 5 seconds, or you'll add 30 more minutes to the recording.

On-Screen Timer Programming

* Refer to the illustration on page 23.

You can directly program the VCR's timer to record up to 8 shows, as far as a year in advance. Remember, the clock must be set before you can program the timer (☞ pg. 7).

LOAD A CASSETTE

Make sure the record safety tab is intact. If not, cover the hole with adhesive tape, then load.

- The VCR comes on, and the counter is reset, automatically.

ACCESS PROGRAM SET SCREEN

Press **MENU**, then press **OK**.

PROGRAM 1	
DATE	--/--
START	--:-- AM
STOP	--:-- AM
CHANNEL	-- SP
PRESS NUMBER KEY(0-9) OR (▲, ▼), THEN (OK) PRESS (MENU) TO END	

CONTINUED ON NEXT PAGE.

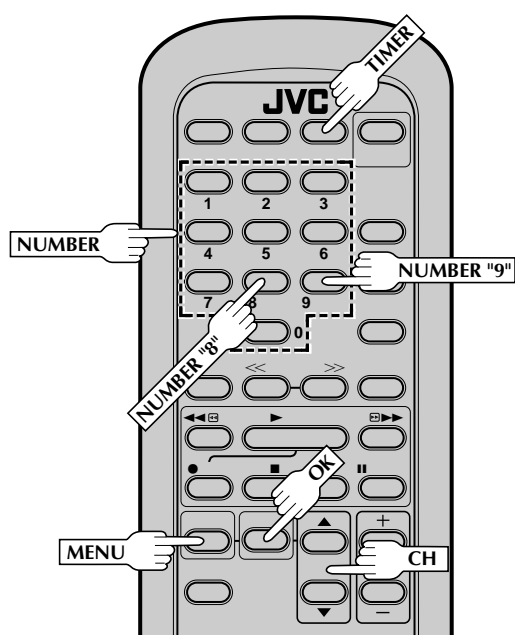
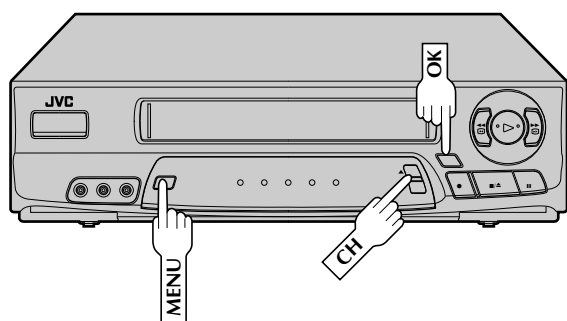
**EXAMPLE**

If you program the VCR to timer record a show on September 6 on channel 40 from 12:00 noon to 1:00 PM in SP mode, the screen will look like this:

PROGRAM 1	
DATE	9/6 SUN
START	12:00 PM
STOP	1:00 PM
CHANNEL	40 SP
PRESS NUMBER KEY(0-9) OR (▲, ▼), THEN (OK) PRESS (MENU) TO END	

NOTES:

- To disengage the timer before recording starts, press **TIMER** again. Pressing once more re-engages it.
- In case of a power failure after programming, the VCR's memory backup keeps your selections for 10 minutes.
- If you select "PROGRAM SET" without having set the date and time, an error message appears. Follow its instructions.
- If you enter a start time that has already passed, **ERROR** appears on the screen and flashes.
- Programs that start after midnight must have the next day's date.

3 SELECT PROGRAM NUMBER

Press the appropriate **NUMBER** keys or **CH▲▼** to select a vacant program number, then press **OK**. The first time you do this, all numbers will be vacant, so just press **OK** when the screen appears.

4 SET PROGRAM INFORMATION

Press the appropriate **NUMBER** keys to set the date, start/stop time and channel number. Press **CH▲▼** to set AM/PM, channel number and tape speed. Then press **OK** after AM/PM, channel number and tape speed settings. The next setting that can be set begins flashing.

- Any information comprised of 1 digit (except the channel number) should have a "0" entered before it.
- It is possible to set all information using the **CH▲▼** buttons. (In this case, press **OK** after each setting.)

NOTE:

If you are using a cable box, enter the cable box channel, not the channel to be recorded. The channel to be recorded must be selected on the cable box. (The cable box channel is the VCR's channel that displays the channels received by the cable box.)

** You can record selected programs at the same time every weekday, or once a week. Before entering the month, press **NUMBER** key "8" (DAILY) or "9" (WEEKLY). Either "DAILY" or "WEEKLY" appears. Press again and "DAILY" or "WEEKLY" disappears.

5 MAKE CORRECTIONS

To change any of the settings, press **OK** until the item you want to change begins blinking. Then set as in step 4.

6 RETURN TO NORMAL SCREEN

Press **MENU** as many times as necessary.

- Press just once to access the Auto Timer screen (pg. 25).

7 ENGAGE TIMER MODE

Press **TIMER**. The VCR turns off automatically.

- After timer recording is completed, the VCR's power goes off automatically.
- You can program the timer while a regular recording is in progress; the on-screen menu will not be recorded.
- If the end of tape is reached during timer recording, the cassette is automatically ejected.
- When timer-recording cable channels received through a Cable Box, be sure to keep the Cable Box set to ON.

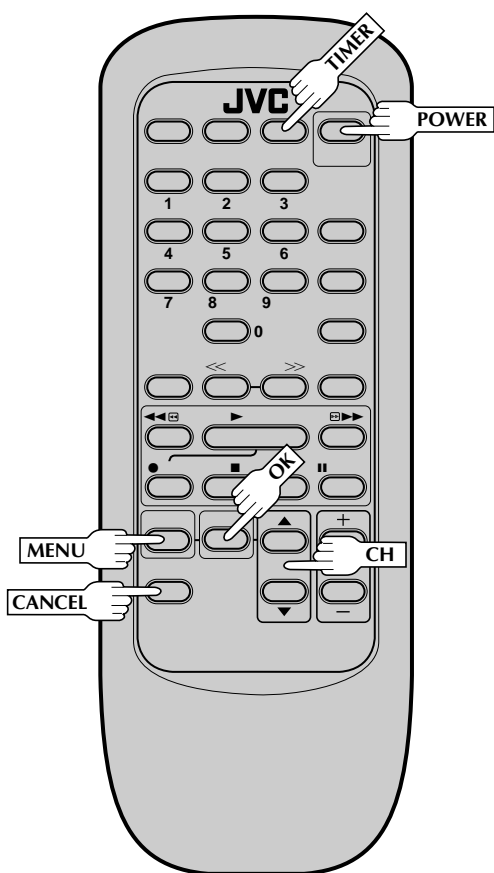
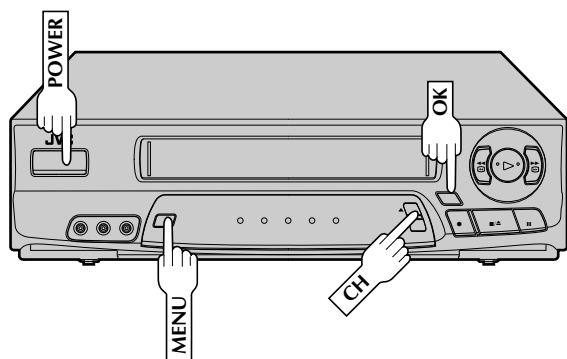

Check And Cancel Programs

- 1** **DISENGAGE TIMER**
Press **TIMER**, then press **POWER**.
- 2** **ACCESS PROGRAM SET SCREEN**
Press **MENU**, then press **OK**.
- 3** **CHECK PROGRAM INFORMATION**
Press **CH▲▼** to check the programs in succession.

To Cancel A Program . . .

- 4** **CANCEL A PROGRAM**
Press **CANCEL**.
• Repeat steps 3 and 4 as many times as necessary.
- 5** **RETURN TO NORMAL SCREEN**
Press **MENU** as many times as necessary. If there are still programs remaining, go to step 6.
- 6** **RE-ENGAGE TIMER**
Press **TIMER** again.

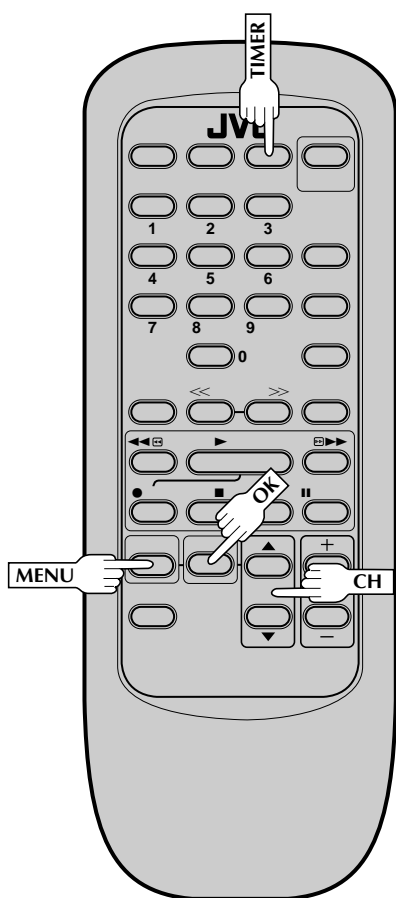
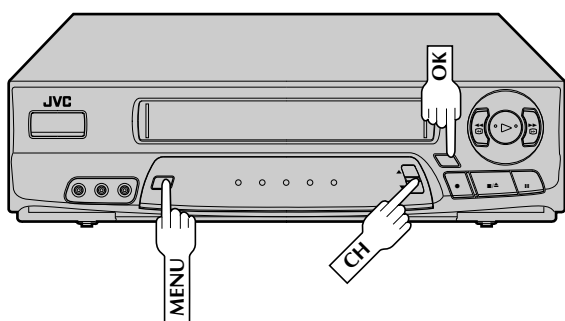

Auto Timer

When activated, this function automatically engages the timer when the VCR's power is turned off, and disengages it when the power is turned on.

1 ACCESS MAIN MENU SCREEN

Press MENU.

2 ACCESS FUNCTION SET SCREEN

Place the arrow next to "FUNCTION SET" by pressing CH▲▼, then press OK.

3 ACCESS AUTO TIMER SCREEN

Place the arrow next to "AUTO TIMER" by pressing CH▲▼, then press OK. Now skip to step 2 of the procedure below.

Or, during on-screen timer programming ...

1 ACCESS FUNCTION SET SCREEN

In step 5 in the On-Screen Timer Programming procedure (pg. 23), press MENU.

2 SELECT MODE

Place the arrow next to your choice ("ON" or "OFF") by pressing CH▲▼.

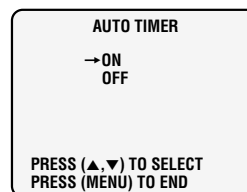

3 RETURN TO NORMAL SCREEN

Press MENU.

NOTE:

For safety, when AUTO TIMER is set to "OFF", all other VCR functions are disabled while the Timer mode is engaged. To disengage the timer, press **TIMER**.



Edit To Or From Another VCR

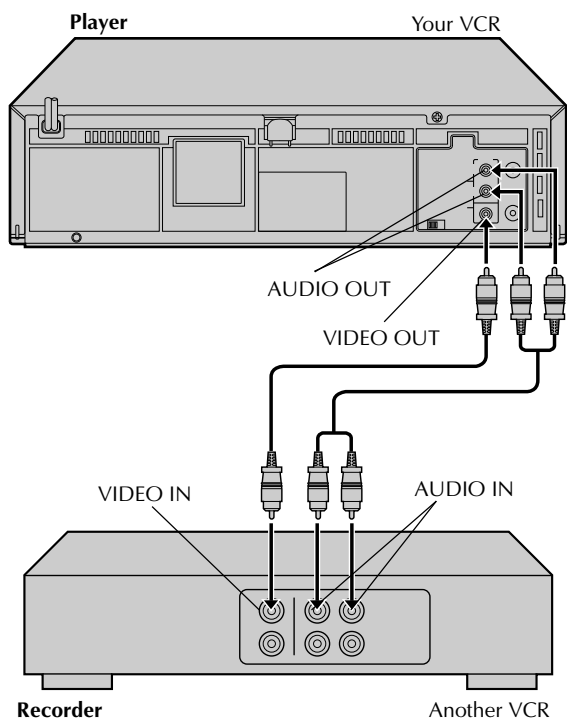

You can use your VCR as the player or the recorder.

1 MAKE CONNECTIONS

Connect an AV cable (not supplied) between the player's VIDEO OUT and AUDIO OUT connectors and the recorder's VIDEO IN and AUDIO IN connectors.

For HR-A52U Owners . . .

- When connecting to a monaural VCR, connect your VCR's AUDIO L IN/OUT connector to the AUDIO IN/OUT connector on the monaural VCR.

For HR-A32U Owners . . .

- When connecting to a Hi-Fi VCR, connect your VCR's AUDIO IN/OUT connector to the AUDIO L IN/OUT connector on the Hi-Fi VCR.

2 LOAD CASSETTES

Insert the playback cassette into the player and the cassette to be recorded on into the recorder.

3 SET RECORDER'S INPUT MODE

Set to AUX. With this VCR, press **NUMBER** key "0".

4 START PLAYER

Set to its play mode.

5 START RECORDER

Set to its record mode.

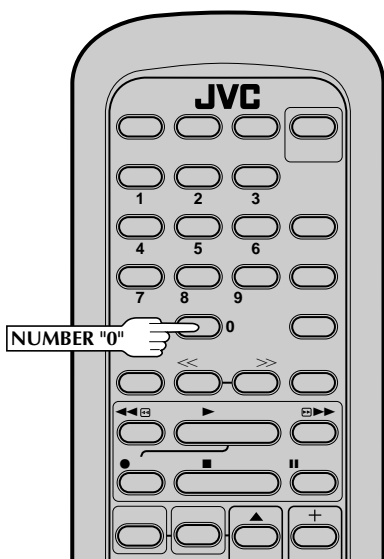



Edit From A Camcorder

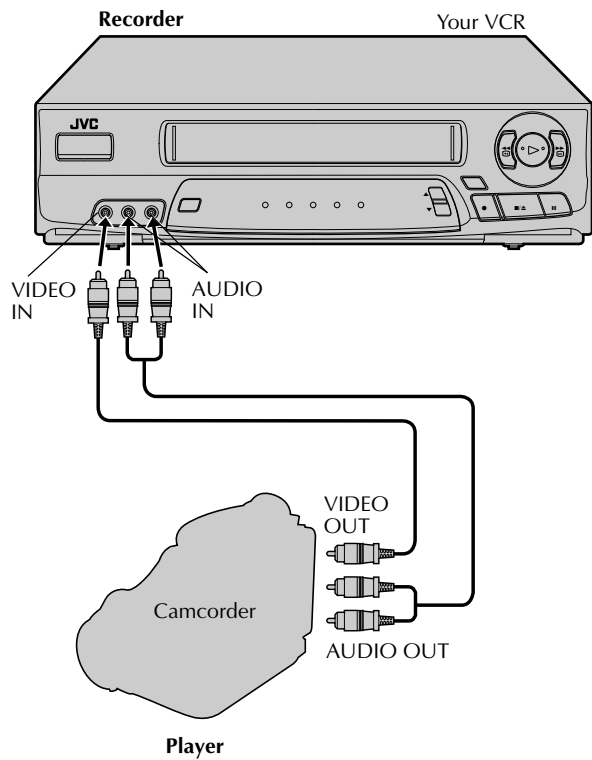

You can use a camcorder as the player and your VCR as the recorder.

1 MAKE CONNECTIONS

Connect an AV cable (not supplied) between the camcorder's VIDEO OUT and AUDIO OUT connectors and your VCR's VIDEO IN and AUDIO IN connectors.

For HR-A52U Owners . . .

- When using a monaural camcorder, connect its AUDIO OUT connector to the AUDIO IN L connector on your VCR.

For HR-A32U Owners . . .

- When using a Hi-Fi camcorder, connect the camcorder's AUDIO OUT L connector to the AUDIO IN connector on your VCR.

2 LOAD A CASSETTE

Insert the cassette to be recorded on into the recorder.

3 SET RECORDER'S INPUT MODE

Set to AUX by pressing **NUMBER** key "0".

4 START PLAYER

Set the camcorder to its play mode.

5 START RECORDER

Set your VCR to its record mode.

- Refer to camcorder/VCR's instruction manual for operation instructions.

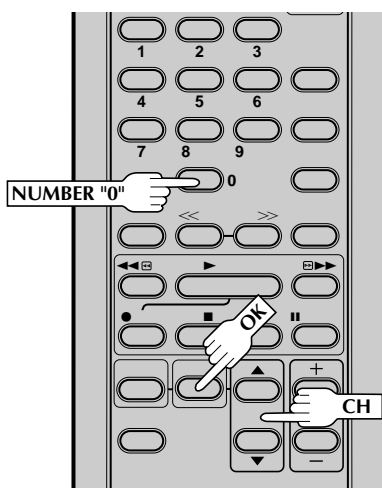

Assemble Editing

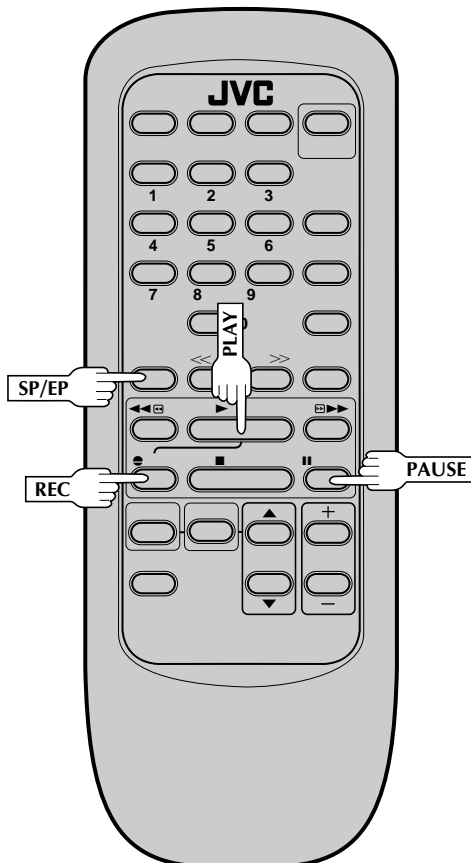
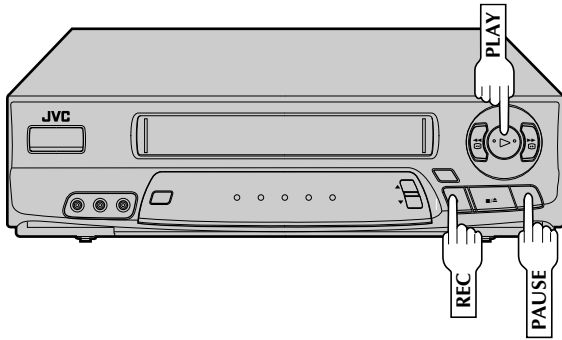

Assemble Editing adds one recorded scene to another in succession.

To use your VCR as the recorder ...

1 LOAD CASSETTES

Insert the original cassette in the player, and the recording cassette in the recorder.

2 SET TAPE SPEED

Set to "SP" or "EP" by pressing the SP/EP button on the remote control.

3 ENGAGE RECORD-STANDBY MODE

Press REC and PAUSE together.

4 FIND EDIT START POINT

Play back the original tape until you reach the scene to be edited.

5 START EDITING

When you reach the scene on the original tape to be edited, press PLAY to initiate the recorder's record mode.

6 STOP EDITING

Press PAUSE to pause the tape in the recorder.

7 CONTINUE EDITING

Repeat steps 4 through 6 to add additional scenes.

NOTE:

Assemble Editing is also possible using your VCR as the playback deck.



Control A JVC TV With The VCR's Remote

You can also use your VCR's remote control to operate a JVC TV.

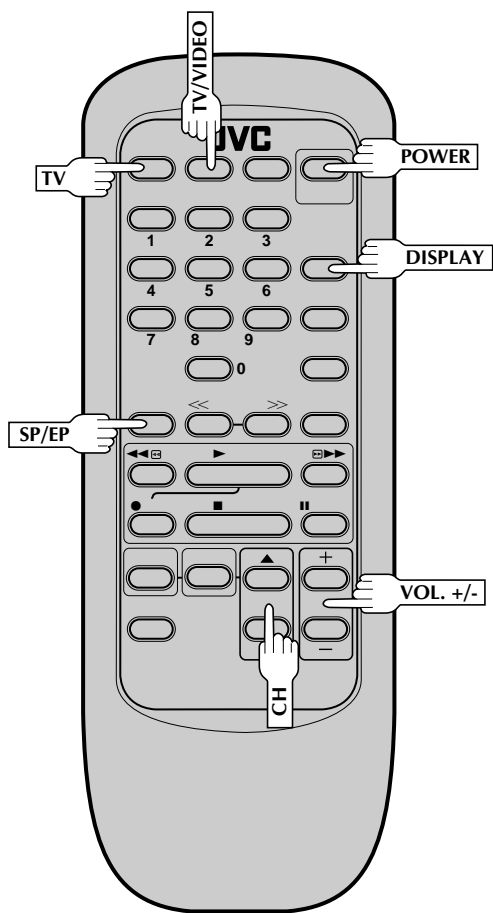

1 OPERATE TV

Press and hold TV, and press POWER, CH▲▼, TV/VIDEO, VOL+/-, DISPLAY (for the TV's on-screen display function), or SP/EP (to select either normal or SAP programs) to operate the TV.

NOTE:

The NUMBER keys cannot be used to change the TV channel.

Before requesting service for a problem, use this chart and see if you can repair the trouble yourself. Small problems are often easily corrected, and this can save you the trouble of sending your VCR off for repair.

POWER		
SYMPTOM	POSSIBLE CAUSE	CORRECTIVE ACTION
1. The power won't come on.	<ul style="list-style-type: none"> • The power cord is disconnected. 	Connect the power cord.
2. The clock works, but the VCR's power won't come on.	<ul style="list-style-type: none"> • The TIMER mode is engaged with Auto Timer set to "OFF" (☞ pg. 25). 	Press TIMER to disengage.
3. The remote control won't function.	<ul style="list-style-type: none"> • The batteries are discharged. 	Replace the dead batteries with new ones.
TAPE TRANSPORT		
SYMPTOM	POSSIBLE CAUSE	CORRECTIVE ACTION
1. The cassette gets stuck partway during loading, and is ejected.	<ul style="list-style-type: none"> • The cassette was inserted incorrectly. 	Make sure the window side is up, the rear label side is facing you and the arrow on the front of the cassette is pointing towards the VCR. Then insert the cassette.
PLAYBACK		
SYMPTOM	POSSIBLE CAUSE	CORRECTIVE ACTION
1. The tape is running but the picture won't appear.	<ul style="list-style-type: none"> • If you're using the RF OUT connection (☞ pg. 6), the channel selector on the TV is set incorrectly. • If you're using the AV connection (☞ pg. 6), the TV receiver is set to the wrong mode. 	Set the channel selector to channel 3 or 4. Set the TV receiver to its AV mode.
2. Noise appears during visual search.	<ul style="list-style-type: none"> • This is normal. 	
3. (HR-A52U only) Breaks are noticeable in Hi-Fi soundtrack.	<ul style="list-style-type: none"> • Automatic tracking is engaged. 	Engage and adjust tracking manually (☞ pg. 15).
4. The playback picture is blurred or interrupted, even though TV broadcasts are clear.	<ul style="list-style-type: none"> • The video heads may be dirty. 	The heads must be cleaned. Consult your JVC dealer (☞ pg. 37).
5. (HR-A52U only) The Hi-Fi soundtrack cannot be heard.	<ul style="list-style-type: none"> • The AUDIO MONITOR option at the Function Set screen was set incorrectly. 	Set AUDIO MONITOR to "HI-FI" (☞ pg. 16).
RECORDING		
SYMPTOM	POSSIBLE CAUSE	CORRECTIVE ACTION
1. Recording won't start.	<ul style="list-style-type: none"> • There's no cassette loaded. • The loaded cassette has had its record safety tab removed. 	Insert a cassette. Remove the cassette and cover the hole with adhesive tape, or load a cassette on which the record safety tab is intact.
2. TV broadcasts won't record properly.	<ul style="list-style-type: none"> • The VCR has been set to its AUX mode by mistake. 	Set the VCR to the appropriate channel.
3. Tape-to-tape editing won't work.	<ul style="list-style-type: none"> • The VCRs or the camcorder and the VCR have been incorrectly connected. • The power to one or more of the units has not been turned on. 	Refer to the directions and the illustration under "Edit To And From Another VCR" (☞ pg. 26) or "Edit From A Camcorder" (☞ pg. 27) and properly connect the units. Make sure the power to all units is on.

TIMER RECORDING

SYMPTOM	POSSIBLE CAUSE	CORRECTIVE ACTION
1. Timer recording won't work.	<ul style="list-style-type: none"> • The clock and/or the timer have been set incorrectly. • The timer is not engaged. • The VCR has not been set up properly. 	Check or re-perform the clock/timer settings to ensure correctness. Press TIMER and check to make sure that the Timer indicator on the front panel lights. Re-perform the set-up procedures.
2. On-screen timer programming won't work.	<ul style="list-style-type: none"> • Timer recording is in progress. 	Timer programming can't be performed when timer recording is in progress. Wait until it finishes.
3. The Timer indicator on the front of the VCR won't stop blinking.	<ul style="list-style-type: none"> • The timer is engaged but there's no cassette loaded. 	Load a cassette with the record safety tab intact, or with the hole covered with adhesive tape.
4. The cassette is automatically ejected, and the Timer indicator on the front of the VCR won't stop blinking.	<ul style="list-style-type: none"> • The loaded cassette has had its record safety tab removed. 	Remove the cassette and cover its hole with adhesive tape, or replace it with a cassette on which the safety tab is intact.
5. The Timer indicator on the front of the VCR blinks for 10 seconds and the timer mode is disengaged.	<ul style="list-style-type: none"> • TIMER has been pressed when there are no programs in memory, or the timer record program information has not been programmed correctly. 	Check the programmed data and re-program as necessary, then press TIMER again.
6. The cassette is automatically ejected, the power shuts off and the Timer indicator on the front of the VCR won't stop blinking.	<ul style="list-style-type: none"> • The end of tape was reached during timer recording. 	The program may not have been recorded in its entirety. Next time make sure you have enough time on the tape to record the entire program.

OTHER PROBLEMS

SYMPTOM	POSSIBLE CAUSE	CORRECTIVE ACTION
1. When scanning channels, some of them are skipped over.	<ul style="list-style-type: none"> • Those channels have been preset to be skipped. 	If you need the skipped channels, restore them (see pg. 11).
2. The channel can't be changed.	<ul style="list-style-type: none"> • Recording is in progress. 	Press PAUSE to pause the recording, change channels, then press PLAY to resume recording.

ATTENTION:

This recorder contains microcomputers. External electronic noise or interference could cause malfunctioning. In such cases, switch the power off and unplug the power cord. Then plug it in again and switch power on. Take out the cassette. After checking the cassette, operate the unit as usual.



PLAYBACK

Q. What happens if the end of the tape is reached during playback or search?

A. The tape is automatically rewound to the beginning.

Q. Can the VCR indefinitely remain in the still mode?

A. No. It stops automatically after 5 minutes to protect the heads.

Q. During search, slow, still and frame-by-frame playback, I can't hear any audio. What's the problem?

A. This is normal.

Q. During search, still and frame-by-frame playback, the picture is intermittent. What's the cause?

A. Picture loss occurs when these types of playback are attempted with a tape recorded in LP mode. Pressing **PLAY** to return to normal playback will restore the picture.

Q. When returning from multi-speed search to normal playback, the picture is disturbed. Should I be concerned about this?

A. No, it is normal.

Q. Noise bars appear during multi-speed search. What's the problem?

A. This is normal.

Q. Other than preventing further recording, what effect does removing the safety tab have?

A. It disables marking of index codes.

Q. Sometimes, during Index Search, the VCR can't find the program I want to see. Why not?

A. There may be index codes too close together.

Q. During playback, on-screen operational indicators sometimes jitter. Why does this happen?

A. If the condition of the tape being played back is not good, jittering of the video (including on-screen indicators) may occur.

RECORDING

Q. When I pause and then resume a recording, the end of the recording before the pause is overlapped by the new recording. Why does this happen?

A. This is normal. It reduces distortion at the pause and resume points.

Q. Can the VCR indefinitely remain in the Record-Pause mode?

A. No. The VCR automatically goes to its Stop mode after 5 minutes to protect the heads. When paused during Instant Timer Recording (ITR), the VCR shuts off automatically after 5 minutes.

Q. What happens if the tape runs out during recording?

A. The VCR automatically rewinds it to the beginning.

TIMER RECORDING

Q. REC and TIMER indicators remain lit on the front panel. Is there a problem?

A. No. This is a normal condition for a timer recording in progress.

Q. Can I program the timer while I'm watching a tape or a TV broadcast?

A. You won't see the picture as it is replaced by the on-screen menu, but the audio from the program or tape you're viewing is present.



List Of Terms

This guide serves as a quick way to locate frequently used terms and on-screen display names. The first page on which the term appears is listed. Most terms appear more than once in the instruction manual.

A

Add Channel	11
AFC.....	11
Audio Monitor	16
Auto Channel Setting	10
Auto Timer	25
Automatic Tracking	15
AV Connection	6

B

Band	9
------------	---

C

Cancel Program	24
Cassette Adapter.....	12
Check Program	24
Connection to TV	6
Contents	5
Counter Reset.....	19

D

Delete Channel	11
----------------------	----

E

Editing.....	26
--------------	----

F

Fast Motion Playback	14
Frame-by-Frame Playback	14
Function Setting	16

I

Index Search	18
Insert Cassette	12
ITR (Instant Timer Recording)	22

L

Language Selection	7
--------------------------	---

M

Main Menu	7
Manual Channel Setting	11
Manual Tracking	15

N

Next-Function Memory	19
----------------------------	----

O

On-Screen Display	17
-------------------------	----

P

Playback	12
Program Setting	22

R

Record Safety Tab	13
Recording	13
Repeat Playback.....	18
Reverse Motion Playback	14
Reverse Playback	14
Reverse Slow Motion Playback	14
RF Connection	6

S

SAP (Second Audio Program)	21
Second Audio	21
Skip Search	18
Slow Motion Playback	14
Specifications	36
Still Playback	14
Superimpose	17

T

Tape Position Indicator	19
Tape Speed Setting	13
Timer Programming.....	22
Timer Recording	22
Tuner Setting	9

FRONT VIEW

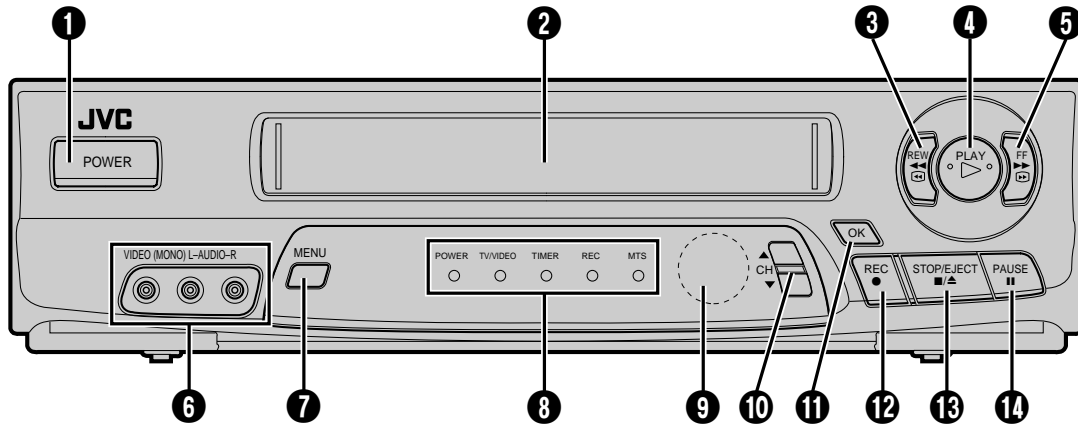

- ❶ Power ON/OFF Button (☞ pg. 7)
 - ❷ Menu Button (☞ pg. 7)
 - ❸ Rewind Button (☞ pg. 12)
 - ❹ Play Button (☞ pg. 12)
 - ❺ Fast-Forward Button (☞ pg. 12)
 - ❻ Video and Audio Input Connectors (☞ pg. 27)
 - ❼ Reverse Search Button (☞ pg. 14)
 - ❽ Forward Search Button (☞ pg. 14)
 - ❾ Front Panel Indicators (☞ pg. 35)
 - ❿ Remote Control Sensor
 - ⓫ Channel ▲▼ Buttons (☞ pg. 7)
 - ⓬ OK Button (☞ pg. 7)
 - ⓭ Record Button (☞ pg. 13)
 - ⓮ Stop/Eject Button (☞ pg. 12)
 - ⓯ Pause Button (☞ pg. 13)
- *The HR-A32U has only one Audio input connector.

REAR VIEW

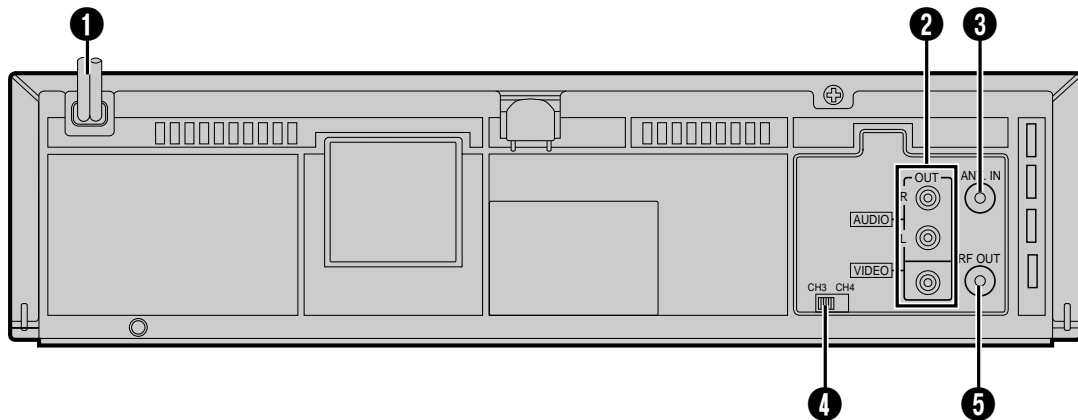

- ❶ Power Cord (☞ pg. 6)
 - ❷ Video and Audio Output Connectors (☞ pg. 6)
 - ❸ ANT. IN Connector (☞ pg. 6)
 - ❹ Channel 3/4 Switch (☞ pg. 6)
 - ❺ RF OUT Connector (☞ pg. 6)
- *The HR-A32U has only one Audio output connector.

FRONT PANEL INDICATORS

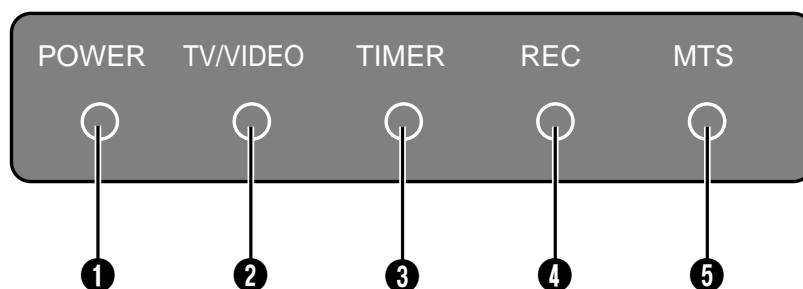

- ❶ Power Indicator
- ❷ Video Mode Indicator (☞ pg. 7)
- ❸ Timer Mode Indicator (☞ pg. 23)
- ❹ Recording Mode Indicator (HR-A52U only) (☞ pg. 13)
- ❺ Multichannel TV Sound Indicators (☞ pg. 21)

REMOTE CONTROL (Provided)

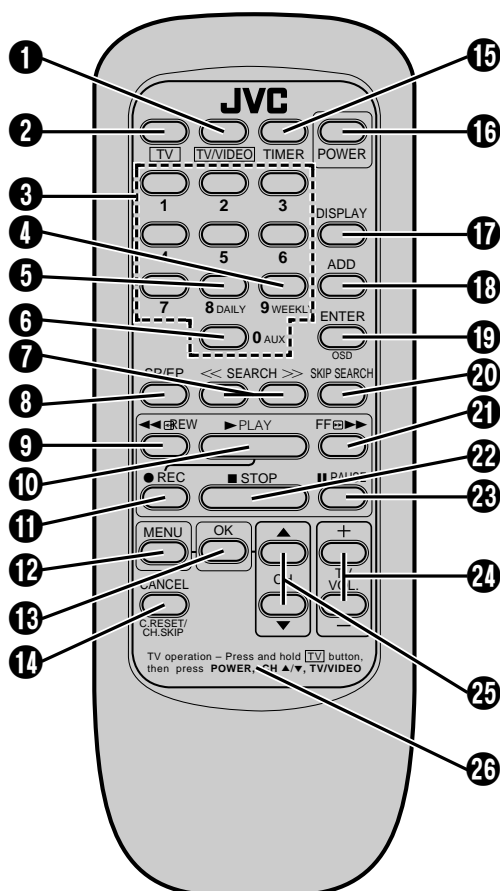

- ❶ TV/VIDEO Button (☞ pg. 7)
- ❷ TV Operation Button (☞ pg. 29)(Refer to ❷ below)
- ❸ NUMBER Buttons (☞ pg. 8)
- ❹ WEEKLY Timer Recording Button (☞ pg. 23)
- ❺ DAILY Timer Recording Button (☞ pg. 23)
- ❻ "AUX" Mode Select Button (☞ pg. 26)
- ❼ Reverse/Forward SEARCH Buttons (☞ pg. 14)
- ❽ Recording Speed [SP/EP] Button (☞ pg. 13)
- ❾ Rewind [REW] Button (☞ pg. 12)
- ❿ PLAY Button (☞ pg. 12)
- ⓫ Record [REC] Button (☞ pg. 13)
- ⓬ MENU Button (☞ pg. 7)
- ⓭ OK Button (☞ pg. 7)
- ⓮ CANCEL Button (☞ pg. 24)
- ⓯ Counter [C.] RESET (☞ pg. 19)
- ⓰ Channel [CH.] SKIP Button (☞ pg. 11)
- ⓱ TIMER Button (☞ pg. 23)
- ⓲ POWER ON/OFF Button (☞ pg. 7)
- ⓳ DISPLAY Button (☞ pg. 19)
- ⓴ ADD Button (☞ pg. 11)
- ⓵ ENTER Button (☞ pg. 13)
- ⓶ On-Screen Display [OSD] Button (☞ pg. 17)
- ⓷ SKIP SEARCH Button (☞ pg. 18)
- ⓸ Fast-Forward [FF] Button (☞ pg. 12)
- ⓹ STOP Button (☞ pg. 12)
- ⓺ PAUSE Button (☞ pg. 13)
- ⓻ Volume [VOL] +/- Buttons (☞ pg. 29)
- ⓼ Channel [CH] ▲▼ Buttons (☞ pg. 7)
- ⓽ Instructions for remote control of the following TV functions: POWER, CH ▲▼ and TV/VIDEO switching.

GENERAL

Power requirement	: AC 120 V \sim , 60 Hz
Power consumption	
(HR-A52U)	: 21 W
(HR-A32U)	: 19 W
Temperature	
Operating	: 5°C to 40°C (41°F to 104°F)
Storage	: -20°C to 60°C (-4°F to 140°F)
Operating position	: Horizontal only
Dimensions (W x H x D)	: 360 x 94 x 276 mm (14-3/16" x 3-3/4" x 10-7/8")
Weight	: 3.4 kg (7.5 lbs)
Format	: VHS NTSC standard
Maximum recording time	
SP	: 210 min. with ST-210 video cassette
EP	: 630 min. with ST-210 video cassette

VIDEO/AUDIO

Signal system	: NTSC-type color signal and EIA monochrome signal, 525 lines/60 fields
Recording/ Playback system	: DA-4 (Double Azimuth) head helical scan system
Signal-to-noise ratio	: 45 dB
Horizontal resolution	: 240 lines
Frequency range	
Normal audio	: 70 Hz to 10,000 Hz
Hi-Fi audio (HR-A52U only)	: 20 Hz to 20,000 Hz
Input/Output	: RCA connectors (IN x 2, OUT x 1)

TUNER

Tuning system	: Frequency-synthesized tuner
Channel coverage	
VHF	: Channels 2-13
UHF	: Channels 14-69
CATV	: 113 Channels
RF output	: Channel 3 or 4 (switchable; preset to Channel 3 when shipped) 75 ohms, unbalanced

TIMER

Clock reference	: Quartz
Program capacity	: 1-year programmable timer/ 8 programs
Memory backup time	: Approx. 10 min.

ACCESSORIES

Provided accessories	: RF cable (F-type), Infrared remote control unit, "AA" battery x 2
----------------------	---

Specifications shown are for SP mode unless otherwise specified. E. & O.E. Design and specifications subject to change without notice.



HOW TO LOCATE YOUR JVC SERVICE CENTER

TOLL FREE: 1-800-252-5722

Dear customer:

In order to receive the most satisfaction from your purchase, read the instruction booklet before operating the unit. In the event that repair is necessary, or for the address nearest your location, please refer to the factory service center list below or within the Continental United States, call 1-800-252-5722 for your authorized servicer. Remember to retain your Bill of Sale for Warranty Service.

— JVC

**JVC SERVICE & ENGINEERING
COMPANY OF AMERICA
DIVISION OF US JVC CORP.**

FACTORY SERVICE CENTER LOCATIONS

107 Little Falls Road
Fairfield, NJ 07004-2105
(201) 808-9279

1500 Lakes Parkway
Lawrenceville, GA 30243-5357
(770) 339-2522

705 Enterprise Street
Aurora, IL 60504-8149
(708) 851-7855

5665 Corporate Avenue
Cypress, CA 90630-0024
(714) 229-8011

10700 Hammerly, Suite 110
Houston, TX 77043-2310
(713) 935-9331

2969 Mapunapuna Place
Honolulu, HI 96819-2040
(808) 833-5828

230 Eliot Street
Ashland, MA 01721-2377
(508) 881-5923

14505 Commerce Way
Miami Lakes, FL 33016-1512
(305) 362-6252

890 Dubuque Avenue
South San Francisco, CA 94080-1804
(415) 871-2666

Sophisticated electronic products may require occasional service. Just as quality is a keyword in the engineering and production of the wide array of JVC products, service is the key to maintaining the high level performance for which JVC is world famous. The JVC service and engineering organization stands behind our products.

NATIONAL HEADQUARTERS
JVC SERVICE & ENGINEERING COMPANY OF AMERICA
DIVISION OF US JVC CORP.
107 Little Falls Road
Fairfield, NJ 07004-2105

If you ship the product...

Pack your JVC unit in the original carton or one of equivalent size and strength. Enclose, with the unit, a letter stating the problem or symptom that exists and also a copy of the receipt or bill of sale you received when you purchased your JVC unit. Print your home return address on the outside and the inside of the carton. Send to the appropriate JVC Factory Service Center as listed above.

Don't service it yourself.

CAUTION

*To prevent electrical shock, do not open the cabinet. No user serviceable parts inside.
Refer servicing to qualified service personnel.*

ACCESSORIES

*To purchase accessories for your JVC product, you may contact your local JVC Dealer.
Or from the 48 Continental United States call toll free:
1-800-882-2345.*

LIMITED WARRANTY**CONSUMER VIDEO 1-90**

JVC COMPANY OF AMERICA warrants this product and all parts thereof, except as set forth below ONLY TO THE ORIGINAL PURCHASER AT RETAIL to be FREE FROM DEFECTIVE MATERIALS AND WORKMANSHIP from the date of original retail purchase for the period as shown below. ("The Warranty Period")

PARTS	1 YR	LABOR	90 DAYS
-------	-------------	-------	----------------

THIS LIMITED WARRANTY IS VALID ONLY IN THE FIFTY (50) UNITED STATES, THE DISTRICT OF COLUMBIA AND IN COMMONWEALTH OF PUERTO RICO.

WHAT WE WILL DO:

If this product is found to be defective, JVC will repair or replace defective parts at no charge to the original owner. Such repair and replacement services shall be rendered by JVC during normal business hours at JVC authorized service centers. Parts used for replacement are warranted only for the remainder of the Warranty Period. All products and parts thereof may be brought to a JVC authorized service center on a carry-in basis except for Television sets having a screen size 25 inches and above which are covered on an in-home basis.

WHAT YOU MUST DO FOR WARRANTY SERVICE:

Return your product to a JVC authorized service center with a copy of your bill of sale. For your nearest JVC authorized service center, please call toll free: (800) 252-5722.

If service is not available locally, box the product carefully, preferably in the original carton, and ship, insured, with a copy of your bill of sale plus a letter of explanation of the problem to the nearest JVC Factory Service Center, the name and location of which will be given to you by the toll-free number.

If you have any questions concerning your JVC Product, please contact our Customer Relations Department.

WHAT IS NOT COVERED:

This limited warranty provided by JVC does not cover:

1. Products which have been subject to abuse, accident, alteration, modification, tampering, negligence, misuse, faulty installation, lack of reasonable care, or if repaired or serviced by anyone other than a service facility authorized by JVC to render such service, or if affixed to any attachment not provided with the products, or if the model or serial number has been altered, tampered with, defaced or removed;
2. Initial installation and installation and removal for repair;
3. Operational adjustments covered in the Owner's Manual, normal maintenance, video and audio head cleaning;
4. Damage that occurs in shipment, due to act of God, and cosmetic damage;
5. Signal reception problems and failures due to line power surge;
6. Video Pick-up Tubes/CCD Image Sensor, Cartridge, Stylus (Needle) are covered for 90 days from the date of purchase;
7. Accessories;
8. Batteries (except that Rechargeable Batteries are covered for 90 days from the date of purchase); from the date of purchase);

There are no other express warranties except as listed above.

THE DURATION OF ANY IMPLIED WARRANTIES INCLUDING THE IMPLIED WARRANTY OF MERCHANTABILITY, IS LIMITED TO THE DURATION OF THE EXPRESS WARRANTY HEREIN.

JVC SHALL NOT BE LIABLE FOR THE LOSS OF USE OF THE PRODUCT, INCONVENIENCE, LOSS OR ANY OTHER DAMAGES, WHETHER DIRECT, INCIDENTAL OR CONSEQUENTIAL (INCLUDING, WITHOUT LIMITATION, DAMAGE TO TAPES, RECORDS OR DISCS) RESULTING FROM THE USE OF THIS PRODUCT, OR ARISING OUT OF ANY BREACH OF THIS WARRANTY. ALL EXPRESS AND IMPLIED WARRANTIES, INCLUDING THE WARRANTIES OF MERCHANTABILITY AND FITNESS FOR PARTICULAR PURPOSE, ARE LIMITED TO THE WARRANTY PERIOD SET FORTH ABOVE.

Some states do not allow the exclusion of incidental or consequential damages or limitations on how long an implied warranty lasts, so these limitations or exclusions may not apply to you. This warranty gives you specific legal rights and you may also have other rights which vary from state to state.

JVC COMPANY OF AMERICA
DIVISION OF US JVC CORP.

41 Slater Drive
Elmwood Park, New Jersey 07407

REFURBISHED PRODUCTS CARRY A SEPARATE WARRANTY, THIS WARRANTY DOES NOT APPLY. FOR DETAILS OF REFURBISHED PRODUCT WARRANTY, PLEASE REFER TO THE REFURBISHED PRODUCT WARRANTY INFORMATION PACKAGED WITH EACH REFURBISHED PRODUCT.

For customer use:

Enter below the Model No. and Serial No. which is located either on the rear, bottom or side of the cabinet. Retain this information for future reference.

Model No.: _____

Serial No.: _____

Purchase date: _____

Name of dealer: _____



39



HR-A52U/A32U

JVC

JVC COMPANY OF AMERICA
DIVISION OF US JVC CORP.
41 Slater Drive, Elmwood Park, N.J. 07407

COPYRIGHT © 1996 VICTOR COMPANY OF JAPAN, LTD.

 Printed in Malaysia
0196HOV*UN*PJ